

# Blondel's Experiment

Kirk T. McDonald

Joseph Henry Laboratories, Princeton University, Princeton, NJ 08544

(June 11, 2010)

## 1 Problem

In 1914, Blondel [1] performed an experiment in which a solenoidal coil was coaxial with a region of static magnetic field, such that the magnetic field on the conductor of the coil was negligible. The conductor of the coil  $T$  ( $D$  in the right figure) could be wound onto an auxiliary drum  $T'$  ( $D_1$ ), such that the magnetic flux through the coil  $T$  ( $D$ ) was time dependent. What was the reading of the galvanometer  $G$  ( $V$ ) when the conductor was in motion?

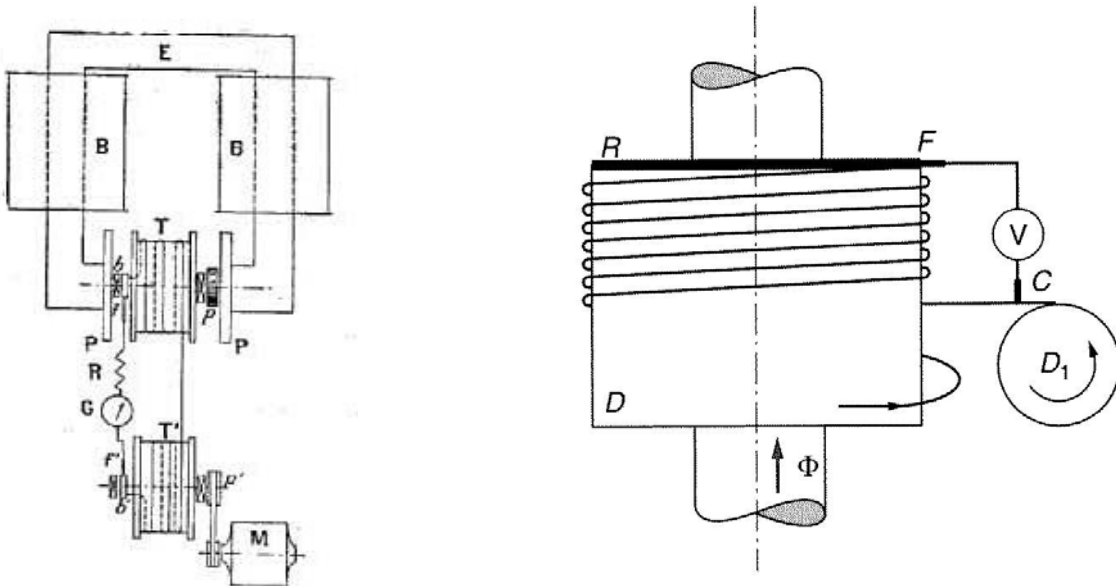

## 2 Solution

Because the magnetic field on the conductor is everywhere “zero”, there is zero  $\mathbf{J} \times \mathbf{B}$  force on the conduction electrons, and no  $\mathcal{EMF}$  is induced in the circuit containing the galvanometer (voltmeter), which therefore has zero reading even though the magnetic flux through this circuit is changing.

This “flux-rule exception” illustrates that one must be cautious in interpreting Faraday’s law as implying that a changing magnetic flux induces an  $\mathcal{EMF}$ .

*This delightful problem is only rarely discussed [2, 3, 4]. It has, however, been recently misinterpreted [5] as providing evidence for the “reality” of the vector potential.*

*For a subtler example of possibly surprising behavior in the “zero-field” region outside a long solenoid magnet with a slowly varying current, see [6].*

## A Appendix: Time-Dependent Electromagnet

In the analysis above we assumed that there was no magnetic field from the electromagnet  $E$  at any point on the conductor of the test circuit. This is a good approximation when the field of the electromagnetic is constant in time.

Suppose, however, the field of the electromagnet varies with time, such that the flux through any turn of the coil on drum  $T$  is  $\Phi_1(t)$ .<sup>1</sup>

Because the drum  $T$  is rotating, the number  $N$  of turns of the coil that link this flux is time dependent. That is, the total flux linked by the test circuit is

$$\Phi = N(t)\Phi_1(t). \quad (1)$$

What is the reading of the galvanometer/voltmeter now, supposing that the total resistance of the test circuit is  $R = R_{\text{wire}} + R_{\text{meter}}$ ?

Here, the  $\mathcal{EMF}$  induced in the test circuit is nonzero, so a small current,

$$I = \frac{\mathcal{EMF}}{R_{\text{wire}} + R_{\text{meter}}}, \quad (2)$$

flows through the meter, whose reading is then<sup>2</sup>

$$V_{\text{meter}} = IR_{\text{meter}} = \mathcal{EMF} \frac{R_{\text{meter}}}{R_{\text{wire}} + R_{\text{meter}}} \approx \mathcal{EMF}. \quad (3)$$

It remains to identify the  $\mathcal{EMF}$  in the test circuit. A direct application of Faraday's flux rule implies that  $\mathcal{EMF} = -d\Phi/dt \equiv -\dot{\Phi} = -N\dot{\Phi}_1 - \dot{N}\Phi_1$ . However, Blondel's experiment reminds us that Faraday's flux rule does not always apply to moving circuits. In particular, we have argued that if  $\Phi_1$  is constant then the  $\mathcal{EMF}$  is zero when  $N$  changes. That is, for the variant of this Appendix,

$$\mathcal{EMF}_0 \approx -N\dot{\Phi}_1. \quad (4)$$

But, there is a small correction to eq. (4) because the sliding conductor moves through the small magnetic field that exists outside the coil due to the small current (2) in the test circuit. This small **motional**  $\mathcal{EMF}$  is similar to that when a bar slides along a U-shaped wire in a transverse magnetic field. As a rough estimate, suppose the length of the wires between drums  $T$  and  $T'$  is  $L$  and the wire that does not contain the galvanometer moves transversely with velocity  $v$ . Then, the magnetic field  $B$  on the moving wire, due to the current  $I = \mathcal{EMF}_0/R$  in the fixed wire (that also runs between the two drums) is

$$B \approx \frac{\mu_0 I}{2\pi x}, \quad (5)$$

when the separation between the two wires is  $x$ . The resulting motional  $\mathcal{EMF}$  (whose sign is the same as that of  $\mathcal{EMF}_0$ ) is

$$|\mathcal{EMF}_{\text{motional}}| \approx IvBL \approx \frac{\mu_0 N^2 \dot{\Phi}_1^2 vL}{2\pi x R^2} \ll |\mathcal{EMF}_0|. \quad (6)$$

---

<sup>1</sup>This variation is posed as prob. 14.22 of [3], where the solution appears to be in error.

<sup>2</sup>We suppose that the characteristic frequency of the time dependence is low enough that the associated wavelength is large compared to the size of the test circuit. Then, radiation can be ignored, and it is relatively straightforward to predict the response of the meter. For a discussion of what voltmeters read in high-frequency applications, see [7].

## References

- [1] A. Blondel, *Sur l'énoncé le plus general des lois de l'induction*, *Compt. Rend. Acad. Sci.* **159**, 674 (1914),  
[http://puhep1.princeton.edu/~mcdonald/examples/EM/blondel\\_cr\\_159\\_674\\_14.pdf](http://puhep1.princeton.edu/~mcdonald/examples/EM/blondel_cr_159_674_14.pdf)
- [2] R.B. Birss, *Electromagnetic Induction*, *Contemp. Phys.* **2**, 281 (1961),  
[http://puhep1.princeton.edu/~mcdonald/examples/EM/birss\\_cp\\_2\\_286\\_61.pdf](http://puhep1.princeton.edu/~mcdonald/examples/EM/birss_cp_2_286_61.pdf)
- [3] Z. Popović and B.D. Popović, *Introductory Electromagnetics – Practice Problems and Labs* (1999), Prob. 14.21,  
[http://puhep1.princeton.edu/~mcdonald/examples/EM/popovic\\_problems.pdf](http://puhep1.princeton.edu/~mcdonald/examples/EM/popovic_problems.pdf)
- [4] A. López-Ramos, J.R. Menéndez and C. Piqué, *Conditions for the validity of Faraday's law of induction and their experimental confirmation*, *Eur. J. Phys.* **29**, 1069 (2008),  
[http://puhep1.princeton.edu/~mcdonald/examples/EM/lopez-ramos\\_ejp\\_29\\_1069\\_08.pdf](http://puhep1.princeton.edu/~mcdonald/examples/EM/lopez-ramos_ejp_29_1069_08.pdf)
- [5] G. Giuliani, *Vector potential, electromagnetic induction and physical meaning*, *Eur. J. Phys.* **31**, 871 (2010),  
[http://puhep1.princeton.edu/~mcdonald/examples/EM/giuliani\\_ejp\\_31\\_871\\_10.pdf](http://puhep1.princeton.edu/~mcdonald/examples/EM/giuliani_ejp_31_871_10.pdf)
- [6] K.T. McDonald, *Lewin's Circuit Paradox* (May 7, 2010),  
<http://puhep1.princeton.edu/~mcdonald/examples/lewin.pdf>
- [7] K.T. McDonald, *What Does an AC Voltmeter Measure?* (March 16, 2008),  
<http://puhep1.princeton.edu/~mcdonald/examples/voltage.pdf>