

Accessing Phases of CKM Matrix Elements Via the Decay $B_d^0 \rightarrow \pi^+\pi^-$

Kirk T. McDonald

Joseph Henry Laboratories, Princeton University, Princeton, NJ 08544

(December 18, 2001)

1 Problem

The combined symmetry CP of charge conjugation (C) and space inversion (parity, P) is expected to be violated in the conjugate decay modes $B_d^0 \rightarrow \pi^+\pi^-$ and $\bar{B}_d^0 \rightarrow \pi^+\pi^-$. As in the $K^0-\bar{K}^0$ system, there is “mixing” in the $B_d^0-\bar{B}_d^0$ system such that one state can oscillate into the other. This makes possible an observable effect of CP violation in the time dependence of the decay of an initially pure B_d^0 meson state, because of interference between CP violating effects in the mixing and in the decay.

You are given that the time evolution of an initially pure B_d^0 meson is

$$|B_{d,\text{phys}}^0(t)\rangle \propto e^{-iMt}e^{-\Gamma t/2} \left(\cos(\Delta Mt/2)e^{-i\phi_M}|B_d^0\rangle + i \sin(\Delta Mt/2) \sqrt{\frac{\langle \bar{B}_d^0|B_d^0\rangle}{\langle B_d^0|\bar{B}_d^0\rangle}} |\bar{B}_d^0\rangle \right), \quad (1)$$

where M and ΔM are the average mass of and the mass difference between the mass eigenstates of the $B_d^0-\bar{B}_d^0$ system, and Γ is the total decay rate of a B_d^0 meson.

The Lagrangian for the charged current (CC) interaction of quarks with the W bosons has the form

$$L^{\text{CC}} = \frac{g}{\sqrt{2}} (\bar{u} \ \bar{c} \ \bar{t})_L \gamma^\mu W_\mu^+ V_{\text{CKM}} \begin{pmatrix} d \\ s \\ b \end{pmatrix}_L + \text{h.c.}, \quad (2)$$

where the Cabibbo-Kobayashi-Maskawa matrix, V_{CKM} , is a 3×3 unitary matrix of coupling constants,

$$V_{\text{CKM}} = \begin{pmatrix} V_{ud} & V_{us} & V_{ub} \\ V_{cd} & V_{cs} & V_{cb} \\ V_{td} & V_{ts} & V_{tb} \end{pmatrix}, \quad (3)$$

that you may approximate as being real numbers with the exception of $V_{td} = |V_{td}|e^{i\phi_{td}}$ and $V_{ub} = |V_{ub}|e^{i\phi_{ub}}$, which have imaginary terms.

Facts: The quark content of the mesons are $B_d^0 = (\bar{b}d)$, $\pi^+ = (\bar{d}u)$, and $\pi^- = (\bar{u}d)$.

- a) Sketch the quark-level Feynman diagrams for the mixing processes $\langle \bar{B}_d^0|B_d^0\rangle$ and $\langle B_d^0|\bar{B}_d^0\rangle$, and determine the dependence of these matrix elements on the V_{CKM} coupling constants. If nature were CP invariant, what would be the relation between the matrix elements?

Assume for simplicity that only t -quarks participate in internal quark lines.

- b) Draw the Feynman diagrams for the conjugate tree-level decay processes $B_d^0 \rightarrow \pi^+\pi^-$ and $\bar{B}_d^0 \rightarrow \pi^+\pi^-$ and extract the dependence of the matrix elements for these processes on the V_{CKM} coupling constants.

There also exist “penguin” diagrams for these decays, which need not be considered here.

- c) Use the results of parts a) and b) to evaluate the time dependence of the decay rate of an initially pure B_d^0 meson to $\pi^+\pi^-$. Identify the effect of CP violation in this.
- d) Use the unitarity constraint on V_{CKM} and your knowledge of the charged current interaction to numerically approximate the ratio of the imaginary parts of V_{ub} and V_{td} ,

$$\frac{\text{Im}(V_{ub})}{\text{Im}(V_{td})}. \quad (4)$$

2 Solution

This problem is a variant of one posed by Chris Tully.

- a) $B_d^0 \rightarrow \bar{B}_d^0$ mixing is described by the two box diagrams:

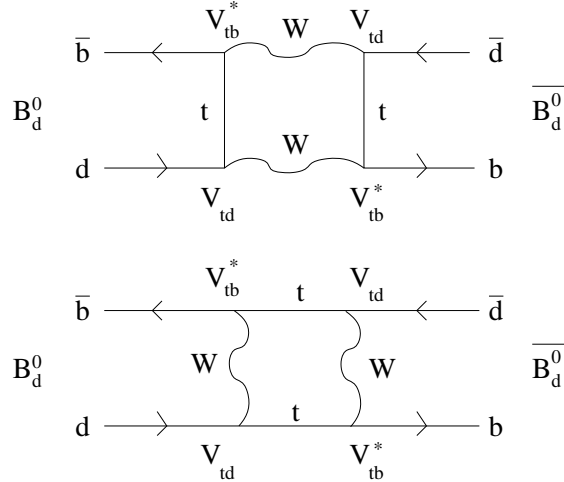

The Lagrangian (2) tells us the vertex involving the d quark in the initial state, and that with the \bar{d} quark in the final state, have coupling factor V_{td} of the V_{CKM} matrix, while the vertex with the \bar{b} quark in the initial state, and that with the b quark in the final state have coupling factor V_{tb}^* of the Hermitian conjugate matrix V_{CKM}^\dagger . Hence, the matrix element is

$$\langle \bar{B}_d^0 | B_d^0 \rangle \propto (V_{td} V_{tb}^*)^2 = V_{tb}^2 |V_{td}|^2 e^{2i\phi_{td}}. \quad (5)$$

The diagrams for the conjugate process $\bar{B}_d^0 \rightarrow B_d^0$ are

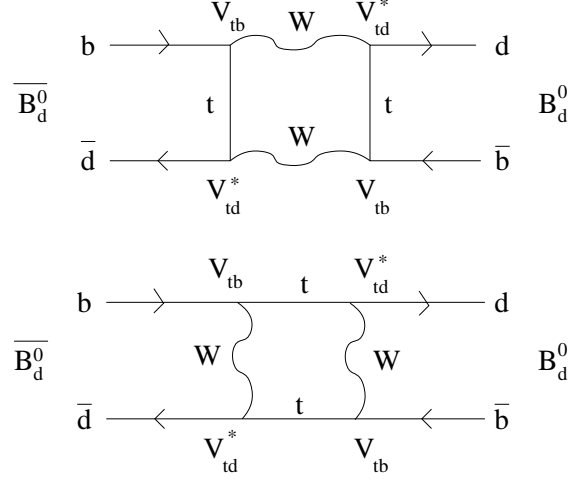

Hence, the matrix element for the conjugate process is

$$\langle B^0 | \bar{B}^0 \rangle \propto (V_{td}^* V_{tb})^2 = V_{tb}^2 |V_{td}|^2 e^{-2i\phi_{td}}. \quad (6)$$

If CP were conserved, the matrix elements for the conjugate processes should have equal values, and hence ϕ_{td} would be zero.

b) The tree diagrams for the decays $B^0(\bar{B}^0) \rightarrow \pi^+\pi^-$ are

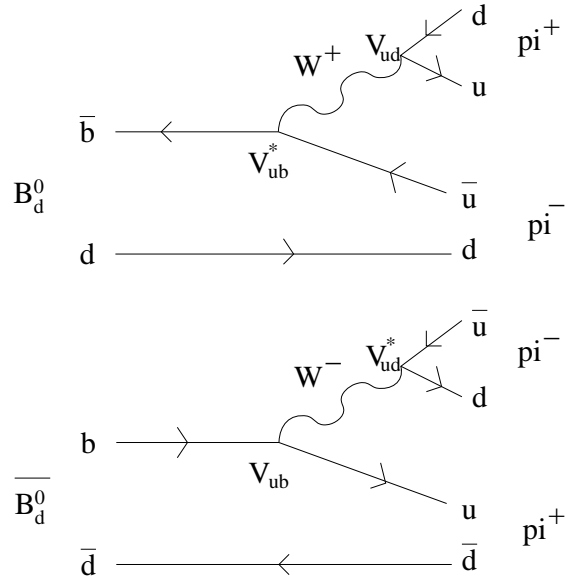

The matrix element for $B^0 \rightarrow \pi^+\pi^-$ is read off of the first diagram as

$$\langle \pi^+\pi^- | B^0 \rangle \propto V_{ud} V_{ub}^* = V_{ud} |V_{ub}| e^{-i\phi_{ub}}. \quad (7)$$

while the matrix element for $\bar{B}^0 \rightarrow \pi^+\pi^-$ is read off of the second diagram as

$$\langle \pi^+\pi^- | \bar{B}^0 \rangle \propto V_{ud}^* V_{ub} = V_{ud} V_{ub} = V_{ud} |V_{ub}| e^{i\phi_{ub}}. \quad (8)$$

Again, if CP were conserved, we expect that these two matrix elements would have equal values (since $\text{CP}|\pi^+\pi^-\rangle = +|\pi^+\pi^-\rangle$ for a spin-0 state), so that ϕ_{ub} would be zero.

The simplicity of the results (7)-(8) is marred by the existence of so-called ‘‘penguin’’ (loop) diagrams for the decay $B^0 \rightarrow \pi^+\pi^-$, which diagrams have different weak phases, and whose amplitudes relative to that of the tree diagrams are difficult to calculate. In principle, the relative amplitudes of the penguin and tree diagrams can be resolved by a combined analysis of the decays $B_d^\pm \rightarrow \pi^\pm\pi^0$, $B_d^0(\bar{B}_d^0) \rightarrow \pi^0\pi^0$, and $B_d^0(\bar{B}_d^0) \rightarrow \pi^+\pi^-$, although this will be quite difficult in practice. See, <http://puhep1.princeton.edu/~mcdonald/tndc/hep-92-09.ps>

- c) Using the results of part a), the time evolution (1) an initially pure B^0 can now be written

$$B_{\text{phys}}^0(t) \propto \cos(\Delta Mt/2)B^0 + i \sin(\Delta Mt/2)e^{2i\phi_{td}}\bar{B}^0. \quad (9)$$

Using the result of part b) the amplitude for the decay of $B_{\text{phys}}^0(t)$ to $\pi^+\pi^-$ can now be written

$$\begin{aligned} \langle \pi^+\pi^- | B_{\text{phys}}^0(t) \rangle &\propto \cos(\Delta Mt/2)e^{-i\phi_{ub}}B^0 + i \sin(\Delta Mt/2)e^{2i\phi_{td}}e^{i\phi_{ub}}\bar{B}^0 \\ &\propto \cos(\Delta Mt/2)B^0 + i \sin(\Delta Mt/2)e^{2i(\phi_{td}+\phi_{ub})}\bar{B}^0, \end{aligned} \quad (10)$$

and the decay rate is

$$\Gamma_{B_{\text{phys}}^0(t) \rightarrow \pi^+\pi^-} \propto \left| \cos(\Delta Mt/2) + i \sin(\Delta Mt/2)e^{2i(\phi_{td}+\phi_{ub})} \right|^2. \quad (11)$$

The interference terms in the rate are

$$\begin{aligned} &i \sin(\Delta Mt/2) \cos(\Delta Mt/2)e^{2i(\phi_{td}+\phi_{ub})} - i \sin(\Delta Mt/2) \cos(\Delta Mt/2)e^{-2i(\phi_{td}+\phi_{ub})} \\ \propto & -\sin 2(\phi_{td} + \phi_{ub}) \sin(\Delta Mt), \end{aligned} \quad (12)$$

which causes a directly measurable change in the time-dependent decay rate due to the CP violating phases ϕ_{td} and ϕ_{ub} .

If we had begun at $t = 0$ with a pure \bar{B}^0 state, the sign of the interference term would be reversed. Hence, the CP violating interference term (12) leads to a nonzero asymmetry of time-dependent rate of decay of initially pure B^0 and \bar{B}^0 states.

To observe the effect (12), we must know that at $t = 0$ the B was in fact a pure B^0 . But in general, B mesons are produced in particle-antiparticle pairs, and both the B and \bar{B} immediately begin to evolve into mixed states. Decays of the second B to final states that are not self conjugate are often used to determine whether it was a B or \bar{B} at the time of its decay. If the B - \bar{B} pair was produced in a pure 2-particle quantum state, then we would know that the first B was the anti of the second B , but only at the moment of the decay of the second particle – even though the two particles are separated in space (EPR paradox).

d) There are 6 unitary constraints from the orthogonality of the rows and columns of the matrix V_{CKM} . Choosing columns 1 and 3,

$$0 = V_{ud}V_{ub}^* + V_{cd}V_{cb}^* + V_{td}V_{tb}^* = V_{ud}V_{ub}^* + V_{cd}V_{cb} + V_{td}V_{tb}. \quad (13)$$

The imaginary part of this relation is

$$-V_{ud}Im(V_{ub}) + Im(V_{td})V_{tb} = 0. \quad (14)$$

Hence,

$$\frac{Im(V_{ub})}{Im(V_{td})} = \frac{V_{tb}}{V_{ud}} = \frac{1}{\cos \theta_C} = \frac{1}{0.97} \approx 1.03. \quad (15)$$

Here we have used the facts that $u \rightarrow d+X$ is a dominant transition with $V_{ud} = \cos \theta_C$, where $\theta_C \approx 0.22$ is the Cabibbo angle, and the process $t \rightarrow b+X$ is dominant transition with $V_{tb} \approx 1$.