

DOES QUANTUM MECHANICS REQUIRE

SUPERLUMINAL CONNECTIONS?

KIRK McDONALD

PRINCETON UNIVERSITY

COLLOQUIUM DEC 3, 1981

THE DIALOGUE INITIATED BY BOHRN AND EINSTEIN AS TO THE INTERPRETATION, COMPLETENESS AND REALITY OF QUANTUM MECHANICAL CONCEPTS CONTINUES TO THE PRESENT DAY. IN THE 1970'S, EXPERIMENTS HAVE CONFIRMED THE STANDARD VIEW OF QUANTUM MECHANICS AND EXCLUDED A LARGE CLASS OF SO-CALLED LOCAL HIDDEN-VARIABLE THEORIES. THIS HAS LED SOME PEOPLE TO SUGGEST THAT QUANTUM MECHANICS REQUIRES 'SUPERLUMINAL CONNECTIONS', WHICH ALLOW TRANSMISSION OF INFORMATION FASTER THAN THE SPEED OF LIGHT. WE DISCUSS A FLAW IN THE ARGUMENT, WHICH RESTORES THE COMPATIBILITY OF RELATIVITY AND QUANTUM MECHANICS.

A mechanical process is therefore accompanied by a wave process, the guiding wave, described by Schrödinger's equation, the significance of which is that it gives the probability of a definite course of the mechanical process.

We think of an incident beam of electrons as having a de Broglie wave associated with it. When it passes over the atom this wave generates a secondary spherical wave; and analogy with optics suggests that a certain quadratic expression formed from the wave amplitude should be interpreted as the current strength, or as the number of scattered electrons.

CAMBRIDGE, *February, 1935.*

MAX BORN.

4 December, 1926

Dear Born

Quantum mechanics is certainly imposing. But an inner voice tells me that it is not yet the real thing. The theory says a lot, but does not really bring us any closer to the secret of the 'old one'. I, at any rate, am convinced that *He* is not playing at dice. Waves in 3-dimensional space, whose velocity is regulated by potential energy (for example, rubber bands). . . I am working very hard at deducing the equations of motion of material points regarded as singularities, given the differential equation of general relativity.

With best wishes

Yours

A. Einstein

15. Schrödinger to Einstein

7, Sentier des Lapins
LaPanne, Belgium
19 July 1939

Dear Einstein,

.
A few months ago a Dutch newspaper carried a report which sounded comparatively intelligent that you have discovered something important about the connection between gravitation and matter waves. I would be terribly interested in that because I have really believed for a long time that the ψ -waves are to be identified with waves representing disturbances of the gravitational potential;

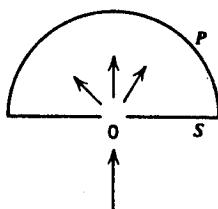

“It seems to me,” Einstein continued, “that this difficulty cannot be overcome unless the description of the process in terms of the Schrödinger wave is supplemented by some detailed specification of the localization of the particle during its propagation. I think M. de Broglie is right in searching in this direction. If one works only with Schrödinger waves, the interpretation II of $|\psi|^2$, I think, contradicts the postulate of relativity.”

Electrons et Photons—Rapports et Discussions du Cinquième Conseil de Physique tenu à Bruxelles du 24 au 29 Octobre 1927 sous les Auspices de l'Institut International de Physique Solvay (Gauthier-Villars, Paris, 1928).

We imagine a photon which is represented by a wave packet built up out of Maxwell waves.

By reflection at a semi-transparent mirror, it is possible to decompose it into two parts, a reflected and a transmitted packet.

The experiment at the position of the reflected packet thus exerts a kind of action (reduction of the wave packet) at the distant point occupied by the transmitted packet, and one sees that this action is propagated with a velocity greater than that of light. However, it is also obvious that this kind of action can never be utilized for the transmission of signals so that it is not in conflict with the postulates of the theory of relativity.

“The Physical Principles of the Quantum Theory”

W. HEISENBERG

LEIPZIG
March 3, 1930

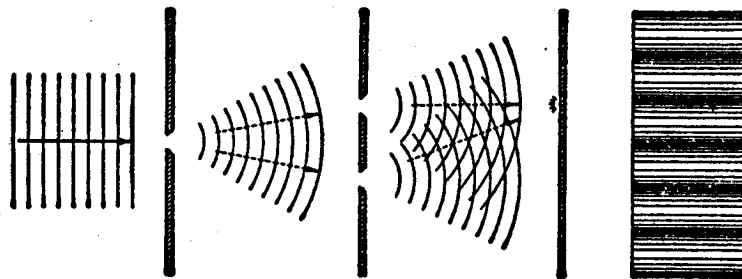

Since, now, as indicated by the broken arrows, the momentum transferred to the first diaphragm ought to be different if the electron was assumed to pass through the upper or the lower slit in the second diaphragm, Einstein suggested that a control of the momentum transfer would permit a closer analysis of the phenomenon and, in particular, to decide through which of the two slits the electron had passed before arriving at the plate.

A closer examination showed, however, that the suggested control of the momentum transfer would involve a latitude in the knowledge of the position of the diaphragm which would exclude the appearance of the interference phenomena in question.

NIELS BOHR

DISCUSSION WITH EINSTEIN

This point is of great logical consequence, since it is only the circumstance that we are presented with a choice of *either* tracing the path of a particle *or* observing interference effects, which allows us to escape from the paradoxical necessity of concluding that the behaviour of an electron or a photon should depend on the presence of a slit in the diaphragm through which it could be proved not to pass. We have here to do with a typical example of how the complementary phenomena appear under mutually exclusive experimental arrangements (cf. p. 210) and are just faced with the impossibility, in the analysis of quantum effects, of drawing any sharp separation between an independent behaviour of atomic objects and their interaction with the measuring instruments which serve to define the conditions under which the phenomena occur.

NIELS BOHR

DISCUSSION WITH EINSTEIN

One of the most fundamental questions raised by recent advance in science is how to reconcile the two contradictory views of matter and wave.

The future must decide whether the solution suggested by modern physics is enduring or temporary.

The Evolution of Physics

COPYRIGHT 1938 BY ALBERT EINSTEIN AND LEOPOLD INFELD

The same experiment is repeated over and over again in exactly the same way; the electrons all have the same velocity and move in the direction of the two pinholes.

The outcome of repeated experiments must again be dark and light rings for one hole and dark and light stripes for two.

Since one particle is indivisible we cannot imagine that it passes through both the holes. The fact that the experiment was repeated many times points to another way out. Some of the electrons may pass through the first hole and others through the second.

If we state only what happens to the crowd of electrons when the experiment is repeated, not bothering about the behavior of individual particles, the difference between the ringed and the striped pictures becomes comprehensible.

The Evolution of Physics

ALBERT EINSTEIN AND LEOPOLD INFELD

15 September, 1950

Dear Born

Take a (macroscopic) body which can rotate freely about an axis. Its state is fully determined by an angle. Let the initial conditions (angle and angular momentum) be defined as precisely as the quantum theory allows. The Schroedinger equation then gives the ψ -function for any subsequent time interval. If this is sufficiently large, all angles become (in practice) equally probable. But if an observation is made (e.g. by flashing a torch), a definite angle is found (with sufficient accuracy). This does not prove that the angle had a definite value before it was observed - but we believe this to be the case, because we are committed to the requirements of reality on the macroscopic scale. Thus, the ψ -function does not express the real state of affairs perfectly in this case. This is what I call 'incomplete description'.

Kind regards

Yours

A. E.

SELF-INTERFERENCE OF A PHOTON

The answer that quantum mechanics gives to the difficulty is that one should consider each photon to go partly into each of the two components, in the way allowed by the idea of the superposition of states. Each photon then interferes only with itself. Interference between two different photons can never occur.

THE PRINCIPLES OF QUANTUM MECHANICS. By P. A. M. DIRAC.

29 *May* 1930.

Interference fringes with feeble light. By G. I. TAYLOR, B.A.,
Trinity College. (Communicated by Professor Sir J. J. Thomson,
F.R.S.)

[Read 25 January 1909.]

Photographs were taken of the shadow of a needle, the source of light being a narrow slit placed in front of a gas flame. The intensity of the light was reduced by means of smoked glass screens.

The time of exposure for the first photograph was obtained by trial, a certain standard of blackness being attained by the plate when fully developed.

The longest time was 2000 hours or about 3 months. In no case was there any diminution in the sharpness of the pattern although the plates did not all reach the standard blackness of the first photograph.

Proc. Camb. Phil. Soc. 15, 114 (1909)

1 PHOTON IN 10^5 TRANSIT TIMES IN
THE APPARATUS

JOOS' EXPERIMENT: VIEW RADIUM INDUCED SCINTILLATION LIGHT THRU A BINOCULAR MICROSCOPE. ARE PHOTONS SPLIT BY PARTIAL REFLECTION IN THE HALF-SILVERED MIRROR INSIDE THE MICROSCOPE?

Joos, Nachweis einer etwaigen einseitigen Intensitätsverteilung.

Physik. Zeitschr. XXIV, 1923.

Herr Einstein: Die Stichhaltigkeit der statistischen Kriterien kann ich nicht so schnell beurteilen. Aber sicher kann ich vom theoretischen Standpunkt sagen, daß bei partieller Reflexion zufällige Verteilung ganzer Quanten über die beiden Wege erfolgen muß.

EINSTEIN: I CANNOT SO QUICKLY JUDGE THE VALIDITY OF THE STATISTICAL CRITERION (USED IN A SEMI-CLASSICAL ARGUMENT). BUT CERTAINLY I CAN SAY FROM A THEORETICAL STANDPOINT THAT IN THE CASE OF PARTIAL REFLECTION THERE MUST FOLLOW A RANDOM DISTRIBUTION OF WHOLE QUANTA AMONG THE TWO PATHS.

Can Quantum-Mechanical Description of Physical Reality Be Considered Complete?

A. EINSTEIN, B. PODOLSKY AND N. ROSEN, *Institute for Advanced Study, Princeton, New Jersey*

(Received March 25, 1935)

In a complete theory there is an element corresponding to each element of reality. A sufficient condition for the reality of a physical quantity is the possibility of predicting it with certainty, without disturbing the system. In quantum mechanics in the case of two physical quantities described by non-commuting operators, the knowledge of one precludes the knowledge of the other. Then either (1) the description of reality given by the wave function in

quantum mechanics is not complete or (2) these two quantities cannot have simultaneous reality. Consideration of the problem of making predictions concerning a system on the basis of measurements made on another system that had previously interacted with it leads to the result that if (1) is false then (2) is also false. One is thus led to conclude that the description of reality as given by a wave function is not complete.

* The deductions contained in the article cited may in this respect be considered as an immediate consequence of the transformation theorems of quantum mechanics, which perhaps more than any other feature of the formalism contribute to secure its mathematical completeness and its rational correspondence with classical mechanics. In fact, it is always possible in the description of a mechanical system, consisting of two partial systems (1) and (2), interacting or not, to replace any two pairs of canonically conjugate variables (q_1, p_1) , (q_2, p_2) pertaining to systems (1) and (2), respectively, and satisfying the usual commutation rules

$$\begin{aligned} [q_1, p_1] &= [q_2, p_2] = ih/2\pi, \\ [q_1, q_2] &= [p_1, p_2] = [q_1, p_2] = [q_2, p_1] = 0, \end{aligned}$$

by two pairs of new conjugate variables (Q_1, P_1) , (Q_2, P_2) related to the first variables by a simple orthogonal transformation, corresponding to a rotation of angle θ in the planes (q_1, p_1) , (q_2, p_2)

$$\begin{aligned} q_1 &= Q_1 \cos \theta - Q_2 \sin \theta & p_1 &= P_1 \cos \theta - P_2 \sin \theta \\ q_2 &= Q_1 \sin \theta + Q_2 \cos \theta & p_2 &= P_1 \sin \theta + P_2 \cos \theta. \end{aligned}$$

Since these variables will satisfy analogous commutation rules, in particular

$$[Q_1, P_1] = ih/2\pi, \quad [Q_2, P_2] = 0,$$

it follows that in the description of the state of the combined system definite numerical values may not be assigned to both Q_1 and P_1 , but that we may clearly assign such values to both Q_1 and P_2 . In that case it further results from the expressions of these variables in terms of (q_1, p_1) and (q_2, p_2) , namely

$$Q_1 = q_1 \cos \theta + q_2 \sin \theta, \quad P_2 = -p_1 \sin \theta + p_2 \cos \theta,$$

that a subsequent measurement of either q_2 or p_2 will allow us to predict the value of q_1 or p_1 respectively.

N. Bohr,

Physical Review 48, 696-702 (1935).

The apparent contradiction in fact discloses only an essential inadequacy of the customary viewpoint of natural philosophy for a rational account of physical phenomena of the type with which we are concerned in quantum mechanics. Indeed the *finite interaction between object and measuring agencies* conditioned by the very existence of the quantum of action entails—because of the impossibility of controlling the reaction of the object on the measuring instruments if these are to serve their purpose—the necessity of a final renunciation of the classical ideal of causality and a radical revision of our attitude towards the problem of physical reality.

N. Bohr, Phys. Rev. 48, 696 (1935).

The two systems are of course supposed not to interact with each other. The entanglement is to be such that the two *commuting* observables

$$x = x_1 - x_2, \quad p = p_1 + p_2, \quad (9)$$

which we choose to represent the state of the *composed* system, have definite numerical values, say x' and p' respectively, which we suppose to be known.

From (9) the variable x can be observed by observing x_1 and x_2 separately, because the latter commute. The difference of the observed values, x'_1 and x'_2 say, must be equal to x' :

$$x'_1 - x'_2 = x'. \quad (11)$$

Hence x'_1 can be predicted from x'_2 and *vice versa*. Similarly

$$p'_1 + p'_2 = p', \quad (12)$$

so that the result of measuring p_1 serves to predict the result for p_2 and *vice versa*.

Yet since I can predict *either* x'_1 or p'_1 without interfering with system No. 1 and since system No. 1, like a scholar in examination, cannot possibly know which of the two questions I am going to ask it first: it so seems that our scholar is prepared to give the right answer to the *first* question he is asked, *anyhow*. Therefore he must know both answers; which is an amazing knowledge, quite irrespective of the fact that after having given his first answer our scholar is invariably so disconcerted or tired out, that all the following answers are "wrong".

E. Schrödinger, "Discussion of probability relations between separated systems," *Proceedings of the Cambridge Philosophical Society* 31, 555-562 (1935)

It is rather discomfoting that the theory should allow a system to be steered or piloted into one or the other type of state at the experimenter's mercy in spite of his having no access to it. This paper does not aim at a solution of the paradox, it rather adds to it, if possible.

$$\Psi(x, y) = \sum_k a_k g_k(x) f_k(y) \quad (12)$$

It seems worth noticing that the paradox could be avoided by a very simple assumption, namely if the situation after separating were described by the expansion (12), but with the additional statement that the knowledge of the *phase relations* between the complex constants a_k has been entirely lost in consequence of the process of separation. This would mean that not only the parts, but the whole system, would be in the situation of a mixture, not of a pure state. It would not preclude the possibility of determining the state of the first system by *suitable* measurements in the second one or *vice versa*. But it would utterly eliminate the experimenters influence on the state of that system which he does not touch.

This is a very incomplete description and I would not stand for its adequateness.

E. Schrödinger, "Probability relations between separated systems," *Proceedings of the Cambridge Philosophical Society* 32, 446-452 (1936).

(Note added Nov. 1, 2003)

The Present Situation In Quantum Mechanics

Erwin Schroedinger

A translation of Schroedingers "cat paradox" paper"

Translator: John D. Trimmer

<http://www.emr.hibu.no/lars/eng/cat/>

This translation was originally published in *Proceedings of the American Philosophical Society*, 124, 323-38. [And then appeared as Section I.11 of Part I of *Quantum Theory and Measurement* (J.A. Wheeler and W.H. Zurek, eds., Princeton university Press, New Jersey 1983).]

5. Are the Variables Really Blurred?

One can even set up quite ridiculous cases. A cat is penned up in a steel chamber, along with the following device (which must be secured against direct interference by the cat): in a Geiger counter there is a tiny bit of radioactive substance, *so* small, that *perhaps* in the course of the hour one of the atoms decays, but also, with equal probability, perhaps none; if it happens, the counter tube discharges and through a relay releases a hammer which shatters a small flask of hydrocyanic acid. If one has left this entire system to itself for an hour, one would say that the cat still lives *if* meanwhile no atom has decayed. The psi-function of the entire system would express this by having in it the living and dead cat (pardon the expression) mixed or smeared out in equal parts.

It is typical of these cases that an indeterminacy originally restricted to the atomic domain becomes transformed into macroscopic indeterminacy, which can then be *resolved* by direct observation. That prevents us from so naively accepting as valid a "blurred model" for representing reality.

Assumption and method A. We assume that during the interaction of the two systems each system made a transition to a definite state, in which it now is, system I being in one of the states φ_{λ_k} and system II in one of the states ξ_{ρ_k} . These transitions are not causally determined, and there is no way of finding out *which* transitions occurred, except by making a suitable measurement.

W. H. Furry,
Physical Review **49**, 393-399 (1936)

On that occasion an interesting discussion arose also about how to speak of the appearance of phenomena for which only predictions of statistical character can be made. The question was whether, as to the occurrence of individual effects, we should adopt a terminology proposed by Dirac, that we were concerned with a choice on the part of "nature" or, as suggested by Heisenberg, we should say that we have to do with a choice on the part of the "observer" constructing the measuring instruments and reading their recording.

NIELS BOHR

DISCUSSION WITH EINSTEIN

But on one supposition we should, in my opinion, absolutely hold fast: the real factual situation of the system S_2 is independent of what is done with the system S_1 , which is spatially separated from the former.

(One can escape from this conclusion only by either assuming that the measurement of S_1 ((telepathically)) changes the real situation of S_2 or by denying independent real situations as such to things which are spatially separated from each other. Both alternatives appear to me entirely unacceptable.)

ALBERT EINSTEIN
AUTOBIOGRAPHICAL NOTES

18 March, 1948

Dear Born

I just want to explain what I mean when I say that we should try to hold on to physical reality. We all of us have some idea of what the basic axioms in physics will turn out to be. The quantum or the particle will surely not be amongst them; the field, in Faraday's and Maxwell's sense, could possibly be, but it is not certain. But whatever we regard as existing (real) should somehow be localised in time and space. That is, the real in part of space A should (in theory) somehow 'exist' independently of what is thought of as real in space B. When a system in physics extends over the parts of space A and B, then that which exists in B should somehow exist independently of that which exists in A. That which really exists in B should therefore not depend on what kind of measurement is carried out in part of space A; it should also be independent of whether or not any measurement at all is carried out in space A. If one adheres to this programme, one can hardly consider the quantum-theoretical description as a complete representation of the physically real. If one tries to do so in spite of this, one has to assume that the physically real in B suffers a sudden change as a result of a measurement in A. My instinct for physics bristles at this. However, if one abandons the assumption that what exists in different parts of space has its own, independent, real existence, then I simply cannot see what it is that physics is meant to describe.

Yours

A. Einstein

Alternative Interpretations of the Quantum Theory

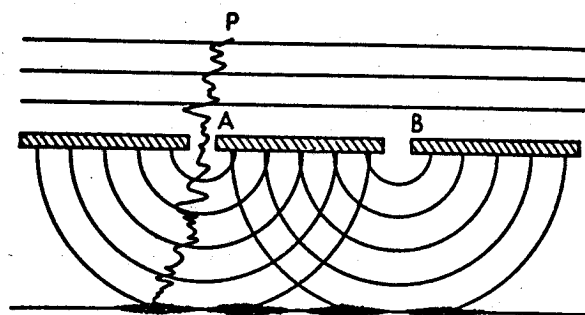

Fig. 6A.

The small body connected with the electron undergoes, however, a random motion. Thus, it follows an irregular path starting out from point P, as indicated in Fig. 6A.

The statistical tendency to appear where $|\psi|^2$ is greatest is due to the effects of the "quantum-force" while the random motions explain why the precise points at which the various particles appear fluctuate in an irregular way.

CAUSALITY AND CHANCE IN MODERN PHYSICS

Copyright 1957 by David Bohm

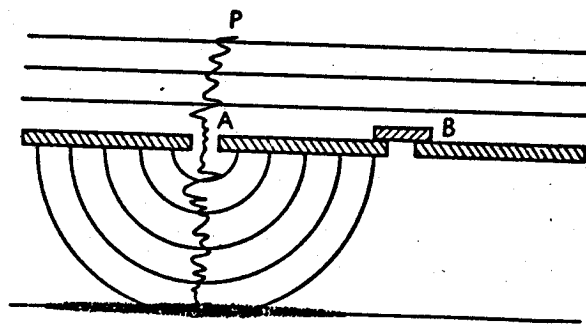

Fig. 6B.

Now suppose that we close slit B. The wave pattern will now, as shown in Fig. 6B, cease to have strong and weak fringes. Thus, a new pattern of electrons is obtained at the screen. Hence, the closing of slit B influences even those particles that pass through slit A, because it influences the "quantum-force" felt by the particle as it moves between the slit system and the screen.

CAUSALITY AND CHANCE IN MODERN PHYSICS

Copyright 1957 by David Bohm

12 May, 1952

Dear Born

Have you noticed that Bohm believes (as de Broglie did, by the way, 25 years ago) that he is able to interpret the quantum theory in deterministic terms? That way seems too cheap to me. But you, of course, can judge this better than I.

Kindest regards to you both

Yours

A. Einstein

We have already remarked that by far the dominating type of annihilation is that in which the positron combines with an electron whose spin forms a singlet state with respect to the spin of the positron.

According to the pair theory, if one of these photons is linearly polarized in one plane, then the photon which goes off in the opposite direction with equal momentum is linearly polarized in the perpendicular plane.

A radioactive source of slow positrons is covered with a foil thick enough to guarantee annihilation of all the positrons. A sphere of lead centered on this source prevents the escape of any of the annihilation quanta, except through a relatively narrow hole drilled through the sphere along one of its diameters.

At each end, a carbon scatterer is placed. Photons scattered by one of these blocks through approximately ninety degrees and into the proper azimuth pass through a gamma ray counter. The scattering process gives a preference to the recording of photons with a selected polarization.

Coincidences between the two counters are recorded, (a) when the azimuths of the two counters are identical, (b) when the azimuths differ by a right angle. The observed ratio of (b) to (a) is compared with the computed ratio, as a check on the theory of the annihilation process. The calculated ratio for the case of ideal geometry is 1.080, when the arrangement requires the photons to be scattered through 90°.

POLYELECTRONS

JOHN ARCHIBALD WHEELER

ANNALS OF THE NEW YORK ACADEMY OF SCIENCES

VOLUME XLVIII, ART. 3. PAGES 219-238

OCTOBER 11, 1946

POSITRONIUM ANNIHILATION AT REST

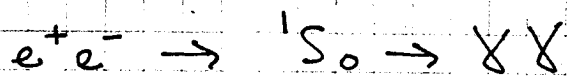

THE TRANSITION OPERATOR IS A SCALAR

IT DEPENDS ON THE PHOTON POLARIZATIONS \vec{E}_1, \vec{E}_2 ,
AND ON THE PHOTON MOMENTUM $\vec{k} = \vec{k}_1 = -\vec{k}_2$

TRANSVERSE POLARIZATION $\Rightarrow \vec{E}_1 \cdot \vec{k} = 0 = \vec{E}_2 \cdot \vec{k}$

POSSIBLE SCALARS ARE

$\vec{E}_1 \cdot \vec{E}_2 \Rightarrow$ POLARIZATIONS IN THE SAME PLANE

$\vec{k} \cdot \vec{E}_1 \times \vec{E}_2 \Rightarrow$ POLARIZATIONS ARE PERPENDICULAR

CONSERVATION OF PARITY

$P(\vec{k}) = -\vec{k}$ BUT $P(\vec{E}_1) = \vec{E}_1$, $P(\vec{E}_2) = \vec{E}_2$

SO $P(\vec{E}_1 \cdot \vec{E}_2) = + \vec{E}_1 \cdot \vec{E}_2$

$P(\vec{k} \cdot \vec{E}_1 \times \vec{E}_2) = - \vec{k} \cdot \vec{E}_1 \times \vec{E}_2$

DIRAC THEORY CLAIMS THE PARITY OF e^+e^- IN 1S_0
IS NEGATIVE

$\therefore \vec{k} \cdot \vec{E}_1 \times \vec{E}_2$ IS THE CORRECT OPERATOR

\Rightarrow PHOTON POLARIZATIONS ARE AT RIGHT ANGLES.

IDEAL POLARIZATION MEASUREMENT

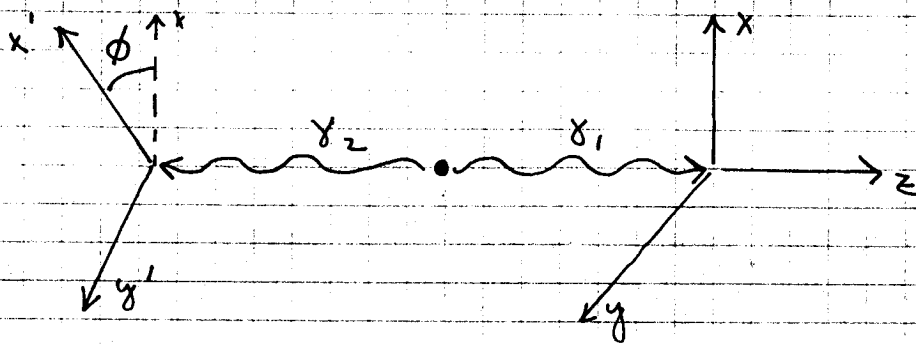

WE USE 2 IDEAL DETECTORS WHICH ONLY RECORD

y_1 IF POLARIZED ALONG THE X AXIS

y_2 IF POLARIZED ALONG THE X' AXIS

ϕ = ANGLE BETWEEN X AND X' AXES

THE WAVE FUNCTION OF THE 2 y 'S FROM e^+e^- DECAY

IS
$$\Psi \sim |x_1 y_2\rangle - |y_1 x_2\rangle$$

NEGATIVE PARITY

WE MUST PROJECT y_2 POLARIZATION ONTO THE X'-Y' AXES

$$|x_2\rangle = \cos \phi |x_2'\rangle - \sin \phi |y_2'\rangle$$

$$|y_2\rangle = \sin \phi |x_2'\rangle - \cos \phi |y_2'\rangle$$

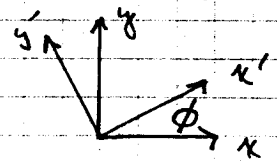

SO
$$\Psi \sim \sin \phi |x_1 x_2'\rangle + \cos \phi |x_1 y_2'\rangle - \cos \phi |y_1 x_2'\rangle + \sin \phi |y_1 y_2'\rangle$$

ONLY THE COMBO $|x_1 x_2'\rangle$ GIVES A SIGNAL

THE RATE IS THEN
$$R(\phi) \sim \sin^2 \phi \sim \underline{1 - \cos 2\phi}$$

$R(\phi = 0^\circ) = 0$ AS EXPECTED.

$R(\phi = 90^\circ) = \text{MAXIMUM}$

INVARIANCE OF ORIENTATION

SUPPOSE WE HAD DEFINED OUR WAVE FUNCTION ALONG THE $x'-y'$ AXES ORIGINALLY.

THEN WE EXPECT

$$\Psi \sim |x_1' y_2'\rangle - |y_1' x_2'\rangle \quad \text{ALSO}$$

THIS FOLLOWS AT ONCE FROM $\Psi \sim |x_1 y_2\rangle - |y_1 x_2\rangle$

AND THE TRANSFORMATION

$$|x_i\rangle = \cos \varphi |x_i'\rangle - \sin \varphi |y_i'\rangle$$

$$|y_i\rangle = \sin \varphi |x_i'\rangle + \cos \varphi |y_i'\rangle$$

$$\begin{aligned} \text{so } \Psi &\sim (\cos \varphi \sin \varphi - \sin \varphi \cos \varphi) |x_1' x_2'\rangle \\ &+ (\cos^2 \varphi + \sin^2 \varphi) |x_1' y_2'\rangle \\ &+ (-\sin^2 \varphi - \cos^2 \varphi) |y_1' x_2'\rangle \\ &+ (-\sin \varphi \cos \varphi + \cos \varphi \sin \varphi) |y_1' y_2'\rangle \\ &= |x_1' y_2'\rangle - |y_1' x_2'\rangle \end{aligned}$$

THE QUANTUM MECHANICS PREDICTION:

$$R(\phi = 0^\circ) = 0, \quad R(\phi = 90^\circ) = \text{MAXIMUM}$$

IS INDEPENDENT OF THE ABSOLUTE ORIENTATION OF THE POLARIZERS.

SINGLE COMPTON SCATTER

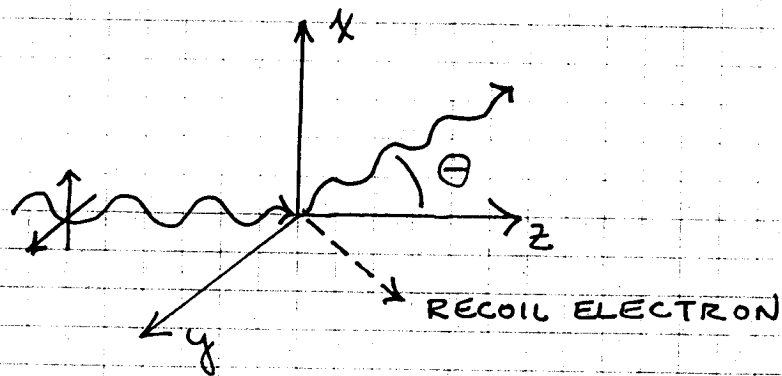

PHOTON POLARIZATION IN X-Z PLANE \Rightarrow RATE $\sim \gamma - 2 \sin^2 \theta$
Y-Z PLANE \Rightarrow RATE $\sim \gamma$

WHERE $\gamma = \frac{K_f}{K_i} + \frac{K_i}{K_f}$ (KLEIN - NISHINA)

SIMPLE CASE : $\theta = 90^\circ$, $K_i = \frac{m_e}{2}$

$\Rightarrow K_f = \frac{1}{2} K_i$, $\gamma = 5/2$

THEN $R_{xz} = 1/2$

$R_{yz} = 5/2$

SCATTERING IS MUCH STRONGER IF POLARIZATION
IS \perp TO PLANE OF SCATTER

[COMPARE WITH RESULT OF CLASSICAL SCATTERING
OF LIGHT OFF ATOMS]

CORRELATIONS IN DOUBLE COMPTON SCATTERING

BLEULER & TER HAAR, SCIENCE 108, 10 (1948)

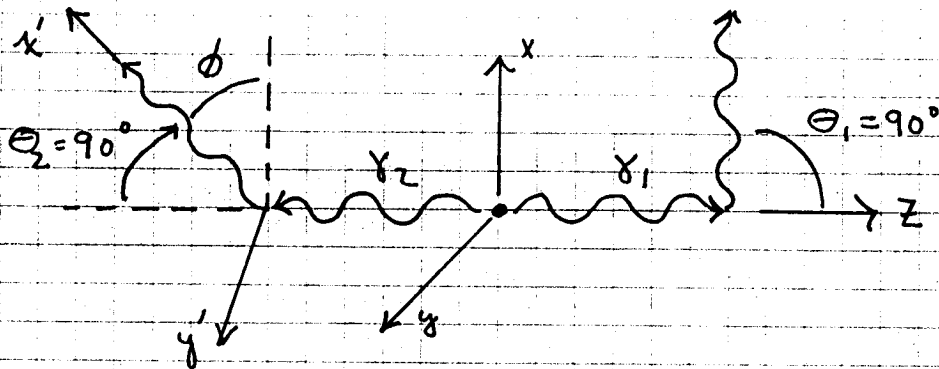

TWO BACK TO BACK PHOTONS FROM e^+e^- ANNIHILATION
 HAVE WAVE FUNCTION $\Psi \sim |x_1, y_2\rangle - |y_1, x_2\rangle$
 NEGATIVE PARITY

EACH PHOTON COMPTON SCATTERS, BUT THE
 SCATTERING PLANES HAVE ANGLE ϕ BETWEEN THEM.

TO USE OUR PREVIOUS RESULT, WE MUST
 PROJECT THE POLARIZATION OF γ_2 ONTO THE x', y' AXES

$$|x_2\rangle = \cos \phi |x_2'\rangle - \sin \phi |y_2'\rangle$$

$$|y_2\rangle = \sin \phi |x_2'\rangle + \cos \phi |y_2'\rangle$$

$$\text{SO } \Psi \sim \sin \phi |x_1, x_2'\rangle + \cos \phi |x_1, y_2'\rangle - \cos \phi |y_1, x_2'\rangle + \sin \phi |y_1, y_2'\rangle$$

THE SCATTERING RATE INTO THE $x-z$, $x'-z'$ PLANES IS

$$R(\phi) \sim \sin^2 \phi \left(\frac{1}{2}\right)\left(\frac{1}{2}\right) + \cos^2 \phi \left(\frac{1}{2}\right)\left(\frac{5}{2}\right) + \cos^2 \phi \left(\frac{5}{2}\right)\left(\frac{1}{2}\right) + \sin^2 \phi \left(\frac{5}{2}\right)\left(\frac{5}{2}\right)$$

$$R(\phi) \sim 1 - \frac{4}{9} \cos 2\phi$$

$$\frac{R(\phi=90^\circ)}{R(\phi=0^\circ)} = \frac{13}{5} = \underline{\underline{2.6}}$$

Correlation between the States of Polarization of the Two Quanta of Annihilation Radiation*

E. BLEULER AND H. L. BRADY**
 Purdue University, Lafayette, Indiana
 April 13, 1948

IT has been pointed out by J. A. Wheeler¹ that according to pair theory the planes of polarization of the two quanta originating in the annihilation of a positron should be perpendicular to each other. This correlation is the equivalent of angular momentum conservation in the process of annihilation of an electron pair with relative velocity zero in the singlet state. The azimuthal variation of intensity of the simultaneous Compton scattering of the two quanta, resulting from this correlation between their respective states of polarization, has been calculated by Pryce and Ward² and by Snyder, Pasternack, and Hornbostel.³ An experimental verification has been attempted with the aid of the arrangement shown in Fig. 1.

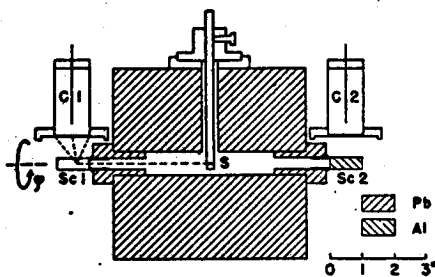

FIG. 1. Coincidence measurement of Compton scattering.

The annihilation radiation of the source S (Cu^{64} , prepared by deuteron irradiation of copper in the Purdue cyclotron) is collimated by a $\frac{1}{2}$ -in. channel in the lead block. The quanta are scattered by cylindrical aluminum scatterers Sc and detected with bell-shaped Geiger counters with lead cathodes. Coincidences were measured for azimuth differences (φ) of 0° , 90° , 180° , and 270° between the counter axes. In order to eliminate all asymmetries both counters were rotated in turn. As a result of absorption in the scatterer the mean scattering angle is slightly less than 90° , near the theoretical maximum of anisotropy calculated for a scattering angle of 82° . Taking into account the finite

TABLE I.

Average single counts without scatterers	3000/min.
Average single counts with scatterers	5370/min.
Chance coincidences ($T = 1.2 \cdot 10^{-3}$ sec.)	0.117/min.
Genuine coincidences C_{\perp}	0.152/min.
Genuine coincidences C_{\parallel}	0.073/min.
Asymmetry ratio C_{\perp}/C_{\parallel}	2.1 ± 0.64

solid angle subtended by the counters, a ratio $C_{\perp}/C_{\parallel} \approx 1.7$ is expected for the coincidence rates at $\varphi = 90^\circ$ (C_{\perp}) and $\varphi = 180^\circ$ (C_{\parallel}). Four different runs were made with different sources consistently showing $C_{\perp} > C_{\parallel}$. Data for a characteristic run of 16 hours are given in Table I.

The observed average asymmetry ratio for all runs is

$$C_{\perp}/C_{\parallel} = 1.94 \pm 0.37.$$

The indicated error is the statistical mean standard deviation. The theoretical prediction is therefore confirmed by this experiment.

* Work done under Navy Contract N6ori-222, Task Order I.

** Now at the University of Rochester, Rochester, New York.

¹ J. A. Wheeler, Ann. N. Y. Acad. Sci. 48, 219 (1946).

² M. H. L. Pryce and J. C. Ward, Nature 160, 435 (1947).

³ H. S. Snyder, S. Pasternack, and J. Hornbostel, Phys. Rev. 63, 440 (1943).

The Angular Correlation of Scattered Annihilation Radiation*

C. S. WU AND I. SHAKNOV

Physics Laboratories, Columbia University, New York, New York
November 21, 1949

AS early as 1946, J. A. Wheeler¹ proposed an experiment to verify a prediction of pair theory, that the two quanta emitted in the annihilation of a positron-electron pair, with zero relative angular momentum, are polarized at right angles to each other. This suggestion involves coincidence measurements of the scattering of both the annihilation photons at various azimuths. The detailed theoretical investigations were reported by Pryce and Ward² and by Snyder, Pasternack, and Hornbostel.³ The predicted maximum asymmetry ratio of coincidence counts when the two counters are at right angles to each other to coincidence counts when the counters are co-planar is as large as 2.85 and occurs at a scattering angle of $\theta = 82^\circ$. Bleuler and Bradt⁴ used two end-window G-M counters as detectors and observed an asymmetry ratio not inconsistent with the theory. Nevertheless, the margin of error associated with their results is so large that a detailed comparison between the theory and experiments is made rather difficult. In the meantime, Hanna⁵ performed similar experiments with more efficient counter arrangements and found the asymmetry ratio observed to be consistently smaller than those predicted. Therefore, it appeared to be highly desirable to reinvestigate this problem by using more efficient detectors and more favorable conditions.

The recently developed scintillation counter has been proved to be a reliable and highly efficient gamma-ray detector. With this improved efficiency, which is around ten times that of G-M counters, there will be an increase in the coincidence counting rate of one hundred times. In our experiments, two RCA 5819 photo-multiplier tubes and two anthracene crystals $1 \times 1 \times \frac{1}{2}$ in. were used. The efficiency for the annihilation radiation obtained with these anthracene crystals is seven to eight percent which compares favorably with the calculated value. The geometrical arrangement is schematically shown in Fig. 1.

The positron source Cu^{64} was activated by deuteron bombardment on a copper target in the Columbia cyclotron. The electroplating method was employed to separate Cu activity from other

contaminations. The active Cu^{64} was packed in a small Al capsule of 8-mm diameter and 8-mm length. The annihilation radiation was collimated by a lead block $6 \times 6 \times 6$ in. with a $\frac{1}{4}$ -in. channel drilled through the center of the block, such that the spread of the beam was found to be less than 3° . The aluminum scatterers were $\frac{1}{2}$ in. in diameter and 1-in. long. They were designed to absorb about 40 percent of the annihilation radiation lengthwise and to limit the multiple scattering of the radiation scattered at 90° to less than 15 percent. The crystal of the counter subtends an angle of 43° at the point in the scatterer where 20 percent of the incident radiation has been absorbed—that is, at the absorption midpoint of the scatterer. The mean scattering angle is very close to 82° , the predicted maximum of anisotropy. Under these conditions, the scattered radiation taken as the counting difference detected by the scintillation counter with and without the scatterer in place is three times the over-all background.

In taking the coincidence measurements, one detector was kept fixed in position, and the second detector was oriented to four different positions with azimuth differences (φ) of 0° , 90° , 180° , and 270° between the detector axis. After that, the second detector was kept fixed and the first one rotated. The total period of measurement lasted about 30 continuous hours. On account of the high coincidence rate observed (the true coincidence rates for the perpendicular position at the beginning was of the order of four per minute), the statistical deviations are much improved as compared to the results from G-M counters. The asymmetry ratio from our best run is

$$\frac{\text{Coincidence counting rate } (\perp)}{\text{Coincidence counting rate } (\parallel)} = 2.04 \pm 0.08,$$

where ± 0.08 is the probable mean error. The calculated asymmetry ratio for our geometrical arrangement is 2.00. Therefore, the agreement is very satisfactory. Further work is being planned to extend the investigations to more ideal geometrical conditions.

We wish to express our appreciation to Professors J. R. Dunning, W. W. Havens, Jr., and L. J. Rainwater for their constant interest and encouragement. We also wish to thank the cyclotron group for preparing the Cu^{64} source and the U. S. AEC which aided materially in the performance of this research.

* Partially supported by the AEC.

¹ J. A. Wheeler, *Ann. New York Acad. Sci.* 48, 219 (1946).

² M. H. L. Pryce and J. C. Ward, *Nature* 160, 435 (1947).

³ Snyder, Pasternack, and Hornbostel, *Phys. Rev.* 63, 440 (1948).

⁴ E. Bleuler and H. L. Bradt, *Phys. Rev.* 73, 1398 (1948).

⁵ R. C. Hanna, *Nature* 162, 332 (1948).

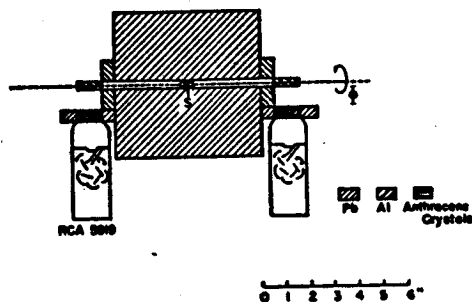
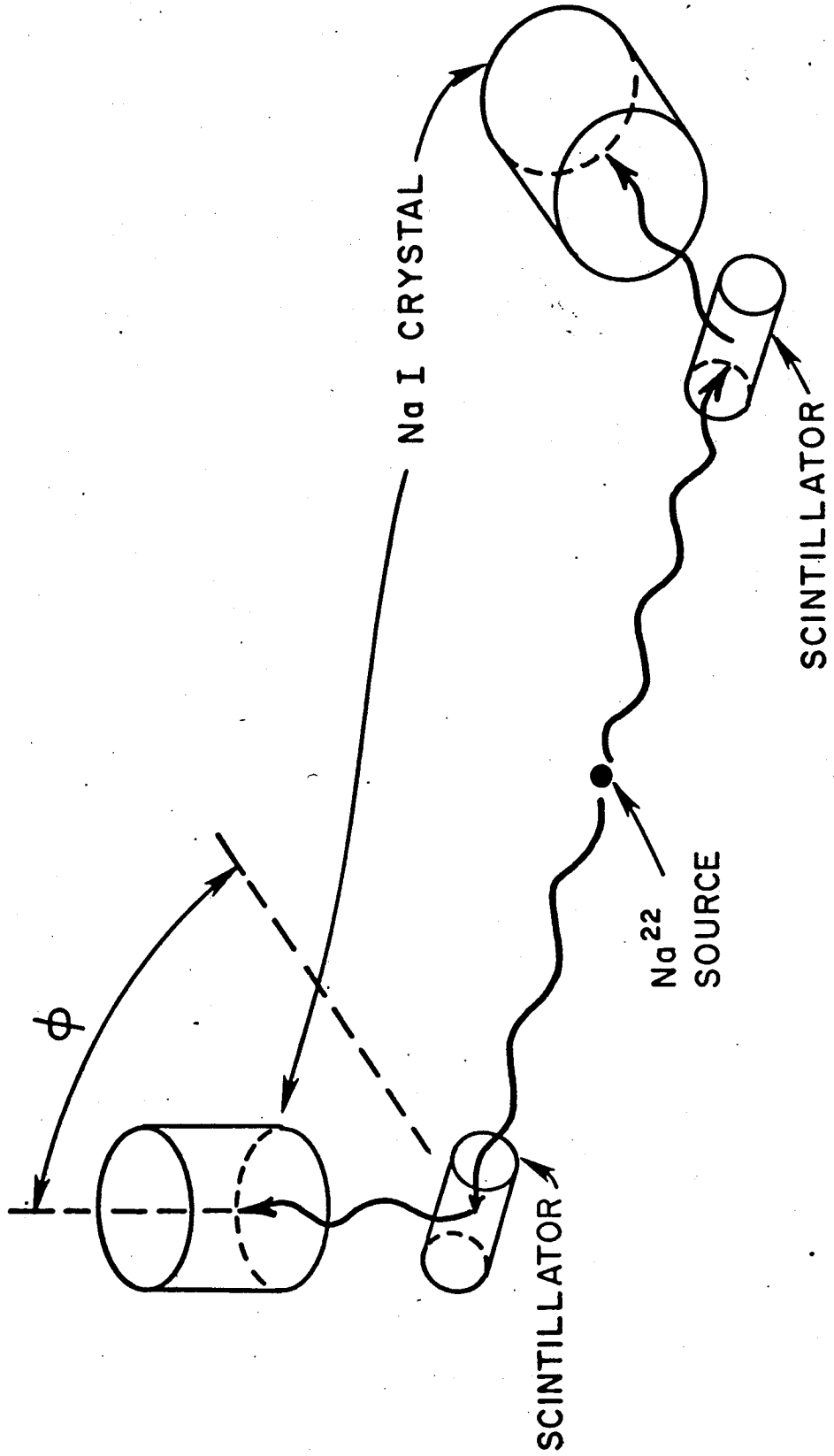
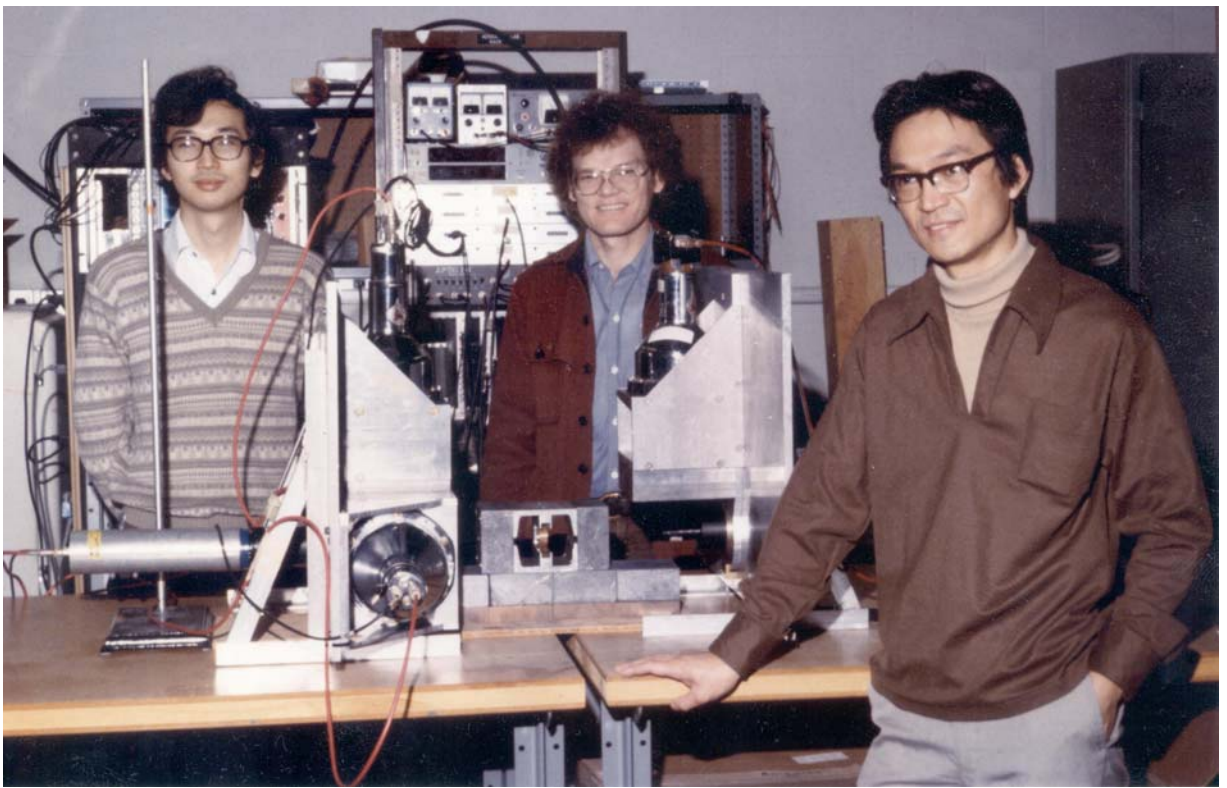

FIG. 1. Schematic diagram of experiment.

POSITRONIUM ANNIHILATION EXPERIMENTS

1. E. BLEULER & H.L. BRADY, PHYS. REV 73, 1398 (1948).
2. R.C. HANNA, NATURE 162, 332 (1948)
3. C.S. WU & I. SHAKNOV, PHYS. REV. 77, 136 (1950)
4. F.L. HEREFORD, PHYS. REV 81, 482 (1951)
5. G. BERTOUNI, M. BETTONI & E. LAZZARINI
NUOVO CIM. 2, 661 (1955)
6. H. LANGHOFF, Z. F. PHYSIK 160, 186 (1960)
7. G. FARACI, D. GUTKOWSKI, S. NOTARRIGO & A.R. PENNISI
LETT. NUOVO. CIM. 9, 607 (1974)
8. L.R. KASDAY, J.D. ULLMAN & C.S. WU, NUOVO CIM. 25B, 633 (1975)
9. A.R. WILSON, J. LOWE & D.K. BUTT, J. PHYS 26, 613 (1976)
10. M. BRUNO, M. D'AGOSTINO & C. MARONI,
NUOVO CIM. 40B, 143 (1977)





LU CHANGCAO & YOSHIHISA KITAZAWA OCT 1981

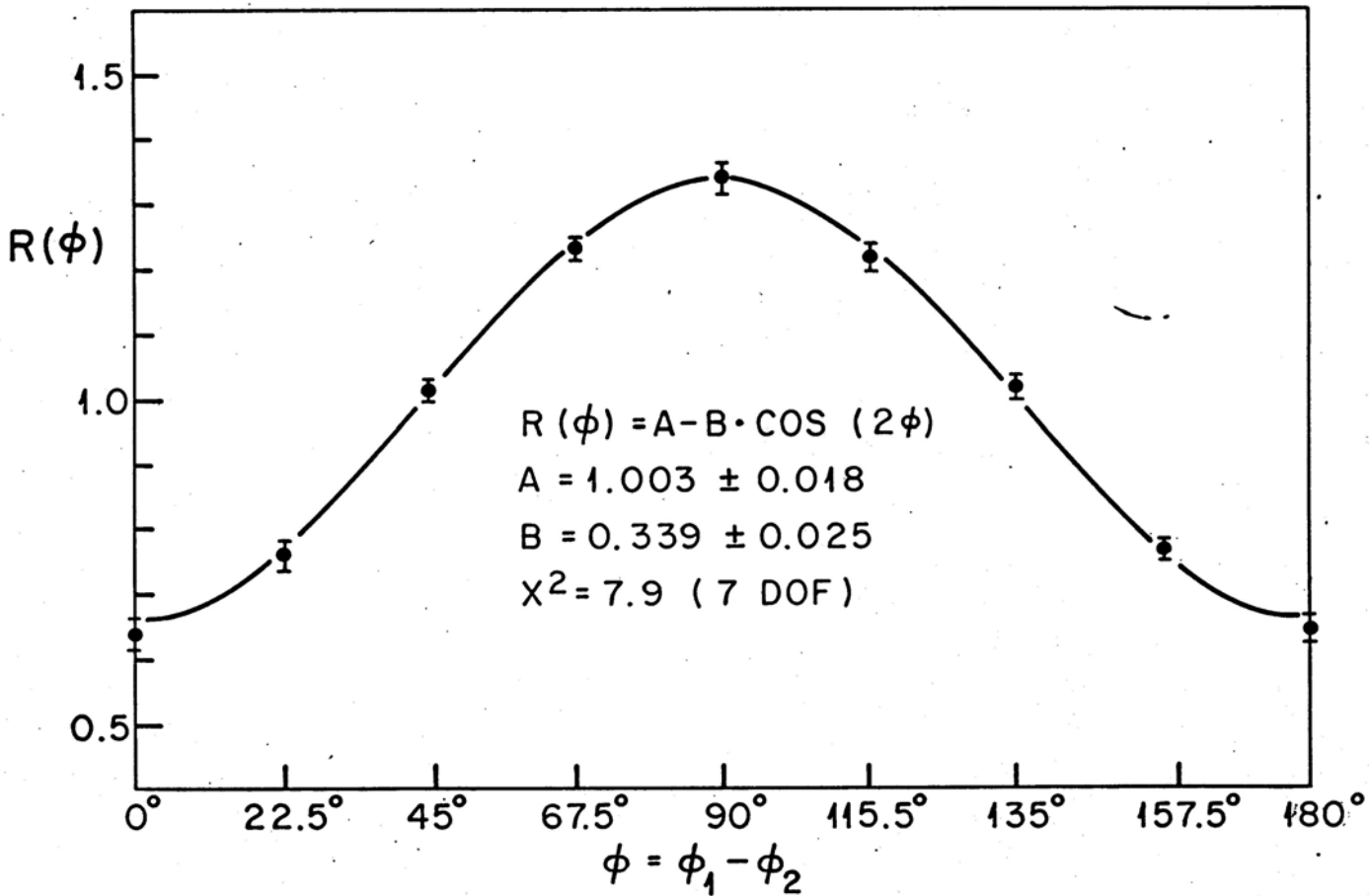

Discussion of Experimental Proof for the Paradox of Einstein, Rosen, and Podolsky

D. BOHM AND Y. AHARONOV

Technion, Haifa, Israel

(Received May 10, 1957)

A brief review of the physical significance of the paradox of Einstein, Rosen, and Podolsky is given, and it is shown that it involves a kind of correlation of the properties of distant noninteracting systems, which is quite different from previously known kinds of correlation. An illustrative hypothesis is considered, which would avoid the paradox, and which would still be consistent with all experimental results that have been analyzed to date. It is shown, however, that there already is an experiment whose significance with regard to this problem has not yet been explicitly brought out, but which is able to prove that this suggested resolution of the paradox (as well as a very wide class of such resolutions) is not tenable. Thus, this experiment may be regarded as the first clear empirical proof that the aspects of the quantum theory discussed by Einstein, Rosen, and Podolsky represent real properties of matter.

RELATION TO THE E-P-R 'PARADOX'

(BOHM - AHARONOV)

SUPPOSE WE HAVE IDEAL POLARIZATION DETECTORS OBSERVING BOTH x AND y POLARIZATIONS FOR BOTH γ_1 AND γ_2 .

THEN, IF x_1 FIRES, SO MUST y_2

OR, IF y_1 FIRES, SO MUST x_2

WE CAN NEVER HAVE x_1, x_2 OR y_1, y_2

HENCE WE CAN DETERMINE THE POLARIZATION OF γ_2 BY A MEASUREMENT OF γ_1 , WHEN γ_1 AND γ_2 ARE WIDELY SEPARATED.

Q QUANTUM MECHANICS CLAIMS THE POLARIZATIONS DID NOT HAVE DEFINITE VALUES PRIOR TO THE MEASUREMENT.

IN PRINCIPLE, THE ORIENTATION OF THE POLARIZERS COULD BE CHOSEN AFTER THE e^+e^- DECAY.

IS A 'SUPERLUMINAL' MESSAGE TRANSMITTED FROM γ_1 TO γ_2 DURING THE MEASUREMENT?

OR IS QUANTUM MECHANICS WRONG, AND THE POLARIZATION ALREADY HAD A DEFINITE VALUE PRIOR TO MEASUREMENT?

THE SCHRÖDINGER-FURRY HYPOTHESIS RECONSIDERED

ONCE THE 2 PHOTONS SEPARATE,
THE POLARIZATION STATE IS DEFINITELY
 $|x_1'' y_2''\rangle$ ALONG SOME AXES x'', y''

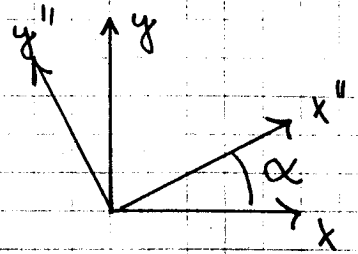

LET α = ANGLE BETWEEN x AND x'' AXES

THEN $\cos^2 \alpha$ = PROB. OF OBSERVING y_1 POLARIZATION
ALONG THE x AXIS

$$\sin^2 \alpha = \text{PROB. OF } y_1 \text{ ALONG } y \text{ AXIS}$$

$$\sin^2 \alpha = \text{PROB. OF } x_2 \text{ " } x \text{ "}$$

$$\cos^2 \alpha = \text{" } x_2 \text{ " } y \text{ "}$$

HENCE PROB. OF OBSERVING POLARIZATION x_1, y_2 IS $\cos^4 \alpha$
PROB. OF x_1, x_2 IS $\sin^2 \alpha \cos^2 \alpha$ ETC.

OF COURSE, α IS RANDOM, SO ON AVERAGE

$$P(x_1, y_2) = 3/8 = P(y_1, x_2)$$

$$P(x_1, x_2) = 1/8 = P(y_1, y_2)$$

BUT STANDARD QUANTUM MECHANICS PREDICTS

$$P(x_1, y_2) = 1/2 = P(y_1, x_2)$$

$$P(x_1, x_2) = 0 = P(y_1, y_2)$$

i.e. $\psi \sim |x_1, y_2\rangle - |y_1, x_2\rangle$ TRANSFORMS TO
 $|x_1'', y_2''\rangle - |y_1'', x_2''\rangle$

SCHRÖDINGER-FURRY HYPOTHESIS INCLUDING

DOUBLE COMPTON SCATTER

THE DEFINITE STATE IS $|x_1'' y_2''\rangle$

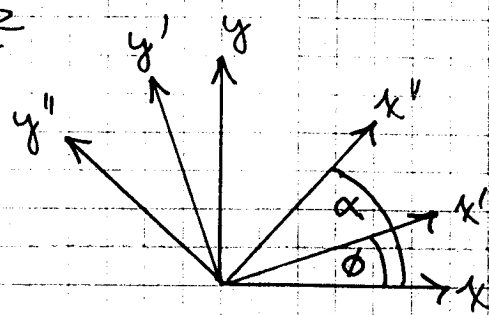

PROJECT γ_1 ONTO x, y AXES:

$$|x_1''\rangle = \cos \alpha |x_1\rangle + \sin \alpha |y_1\rangle$$

PROJECT γ_2 ONTO x', y' AXES:

$$|y_2''\rangle = -\sin(\alpha - \phi) |x_2'\rangle + \cos(\alpha - \phi) |y_2'\rangle$$

$$|x_1'' y_2''\rangle = -\cos \alpha \sin(\alpha - \phi) |x_1 x_2'\rangle + \cos \alpha \cos(\alpha - \phi) |x_1 y_2'\rangle \\ - \sin \alpha \sin(\alpha - \phi) |y_1 x_2'\rangle + \sin \alpha \cos(\alpha - \phi) |y_1 y_2'\rangle$$

THE AVERAGE PROBABILITY OF THE 4 COMBINATIONS IS

$$x_1 x_2' \sim \langle \cos^2 \alpha \sin^2(\alpha - \phi) \rangle \sim \frac{1}{2} + \sin^2 \phi$$

$$x_1 y_2' \sim \langle \cos^2 \alpha \cos^2(\alpha - \phi) \rangle \sim \frac{1}{2} + \cos^2 \phi$$

$$y_1 x_2' \sim \langle \sin^2 \alpha \sin^2(\alpha - \phi) \rangle \sim \frac{1}{2} + \cos^2 \phi$$

$$y_1 y_2' \sim \langle \sin^2 \alpha \cos^2(\alpha - \phi) \rangle \sim \frac{1}{2} + \sin^2 \phi$$

THE DOUBLE COMPTON SCATTERING RATE IS

$$R(\phi) \sim \left(\frac{1}{2} + \sin^2 \phi\right) \left\{ \left(\frac{1}{2}\right)\left(\frac{1}{2}\right) + \left(\frac{5}{2}\right)\left(\frac{5}{2}\right) \right\} + \left(\frac{1}{2} + \cos^2 \phi\right) \left\{ \left(\frac{1}{2}\right)\left(\frac{5}{2}\right) + \left(\frac{5}{2}\right)\left(\frac{1}{2}\right) \right\}$$

$$R(\phi) \sim 1 - \frac{2}{9} \cos 2\phi$$

$$\frac{R(\phi = 90^\circ)}{R(\phi = 0^\circ)} = \frac{11}{7} = 1.57$$

EXCLUDED BY EXPERIMENT!

ON THE EINSTEIN PODOLSKY ROSEN PARADOX*

J. S. BELL†

Department of Physics, University of Wisconsin, Madison, Wisconsin

(Received 4 November 1964)

I. Introduction

THE paradox of Einstein, Podolsky and Rosen [1] was advanced as an argument that quantum mechanics could not be a complete theory but should be supplemented by additional variables. These additional variables were to restore to the theory causality and locality [2]. In this note that idea will be formulated mathematically and shown to be incompatible with the statistical predictions of quantum mechanics. It is the requirement of locality, or more precisely that the result of a measurement on one system be unaffected by operations on a distant system with which it has interacted in the past, that creates the essential difficulty. There have been attempts [3] to show that even without such a separability or locality requirement no "hidden variable" interpretation of quantum mechanics is possible. These attempts have been examined elsewhere [4] and found wanting. Moreover, a hidden variable interpretation of elementary quantum theory [5] has been explicitly constructed. That particular interpretation has indeed a grossly non-local structure. This is characteristic, according to the result to be proved here, of any such theory which reproduces exactly the quantum mechanical predictions.

BELL'S THEOREM

"NO LOCAL HIDDEN VARIABLE THEORY CAN REPRODUCE THE RESULTS OF QUANTUM MECHANICS."

LOCAL MEANS THAT THE STATE OF ONE PART OF THE MEASURING APPARATUS CANNOT AFFECT THE RESULT OBTAIN IN ANOTHER, SPATIALLY SEPARATED PART OF THE APPARATUS.

⇒ IF HIDDEN VARIABLES, THEN SUPERLUMINAL CONNECTIONS

SUMMARY OF 2- γ POLARIZATION CORRELATION THEORIES

$R(\phi)$

	IDEAL POLARIZERS	COMPTON POLARIZERS
QUANTUM MECHANICS	$1 - \cos 2\phi$	$1 - \frac{4}{9} \cos 2\phi$
BOHM - AHARONOV	$1 - \frac{1}{2} \cos 2\phi$	$1 - \frac{2}{9} \cos 2\phi$
BELL'S LIMIT	$1 - \frac{\sqrt{2}}{2} \cos 2\phi$	$1 - \frac{2\sqrt{2}}{9} \cos 2\phi$

KASDAY, ULLMAN & WU EXPERIMENT WITH COMPTON POLARIZERS EXCLUDES BELL'S LIMIT BY 7σ .

ATOMIC CASCADE EXPERIMENTS

1. C. A. KOCHER & E. D. COMINS, P. R. L. 18, 575 (1967).
2. S. J. FREEDMAN & J. F. CLAUSER, P. R. L. 28, 938 (1972).
3. J. F. CLAUSER P. R. L. 36, 1223 (1976)
4. E. S. FRY & R. C. THOMPSON, P. R. L. 37, 465 (1976)
5. A. ASPECT, P. GRANGIER & G. ROGER
P. R. L. 47, 460 (1981)

[EXCLUDES BELL LIMIT BY 13 σ]

SPIN $\frac{1}{2}$ EXPERIMENT (P+P \rightarrow P+P)

1. M. LAMENI-RACHTI & W. MITTIG, P. R. D14, 2543 (1976).

Experimental Tests of Realistic Local Theories via Bell's Theorem

Alain Aspect, Philippe Grangier, and Gérard Roger
Institut d'Optique Théorique et Appliquée, Université Paris-Sud, F-91406 Orsay, France
 (Received 30 March 1981)

We have measured the linear polarization correlation of the photons emitted in a radiative atomic cascade of calcium. A high-efficiency source provided an improved statistical accuracy and an ability to perform new tests. Our results, in excellent agreement with the quantum mechanical predictions, strongly violate the generalized Bell's inequalities, and rule out the whole class of realistic local theories. No significant change in results was observed with source-polarizer separations of up to 6.5 m.

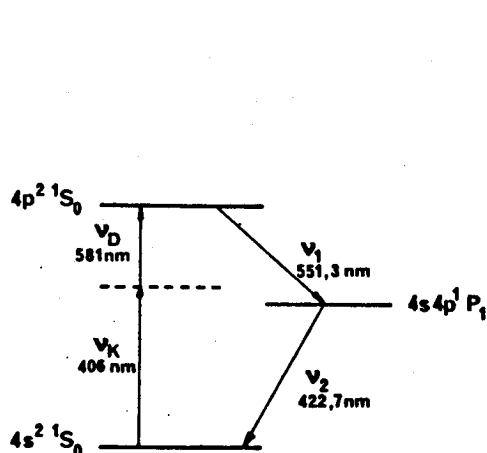

FIG. 1. Relevant levels of calcium. The atoms, selectively pumped to the upper level by the nonlinear absorption of ν_K and ν_L , emits the photons ν_1 and ν_2 correlated in polarization.

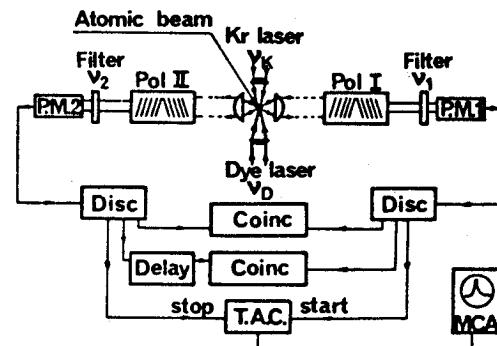

FIG. 2. Schematic diagram of apparatus and electronics. The laser beams are focused onto the atomic beam perpendicular to the figure. Feedback loops from the fluorescence signal control the krypton laser power and the dye-laser wavelength. The output of discriminators feed counters (not shown) and coincidence circuits. The multichannel analyzer (MCA) displays the time-delay spectrum.

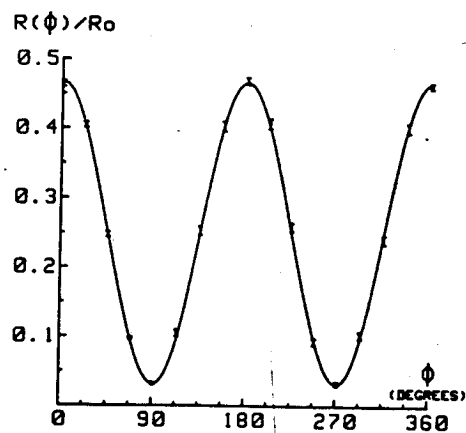
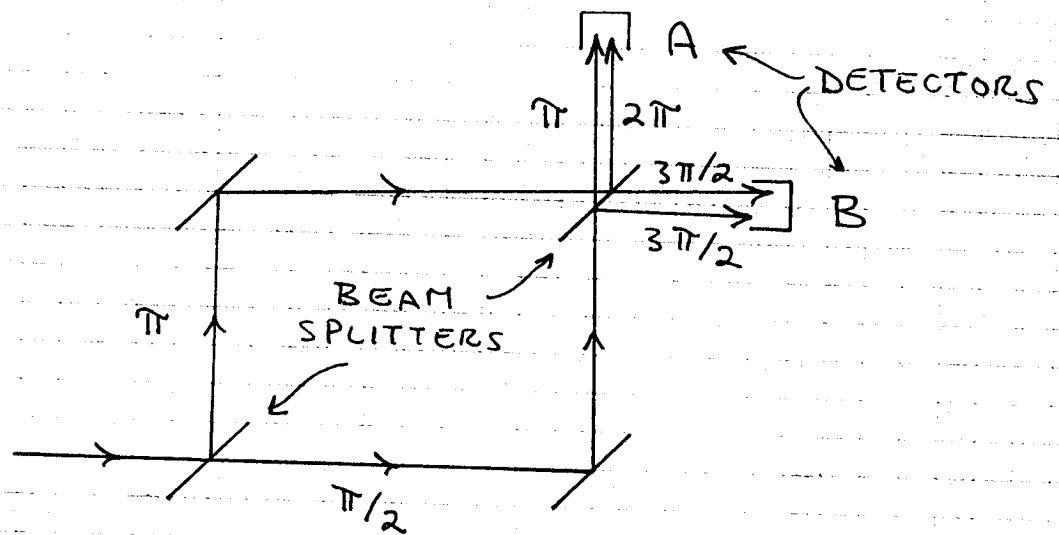

FIG. 4. Normalized coincidence rate as a function of the relative polarizer orientation. Indicated errors are ± 1 standard deviation. The solid curve is not a fit to the data but the prediction of quantum mechanics.

MICHELSON INTERFEROMETER



IN AN IDEAL BEAM SPLITTER THE REFLECTED BEAM UNDERGOES A 180° PHASE CHANGE, AND THE TRANSMITTED BEAM A 90° PHASE CHANGE.

\Rightarrow NO SIGNAL AT A
FULL SIGNAL AT B

THIS IS TRUE FOR SINGLE PHOTONS AS WELL AS LASER BEAMS.

PAIR OF INTERFEROMETERS

REPLACE THE 1ST SPLITTER BY A SOURCE WHICH EMITS PAIRS OF BACK TO BACK PHOTONS.

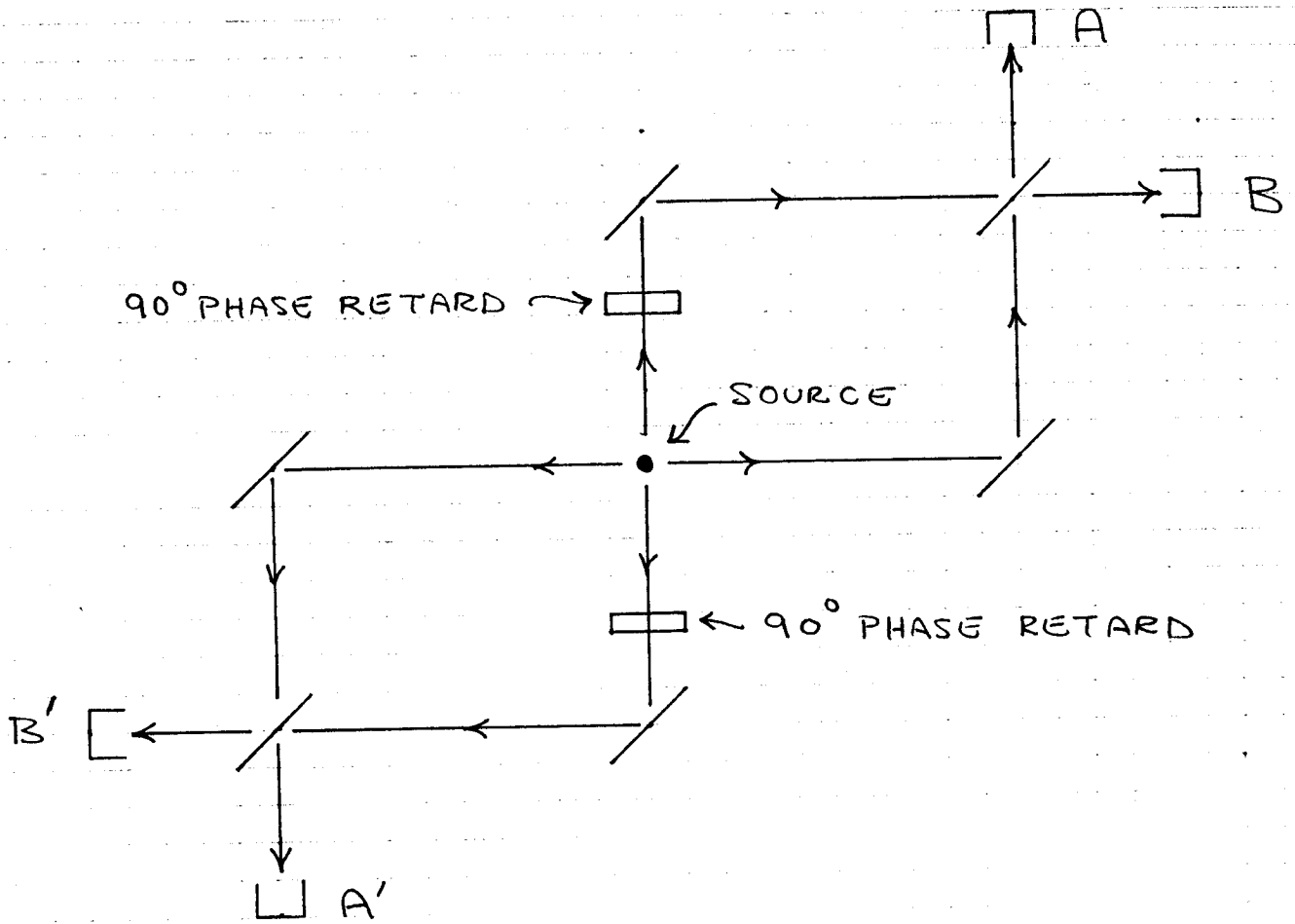

THERE IS INTERFERENCE BETWEEN THE TWO PATTERNS OF EMISSION:

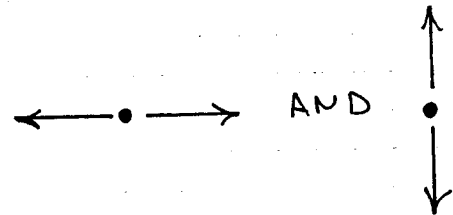

\Rightarrow ONLY SEE SIGNAL IN B AND B',
NEVER IN A OR A'.

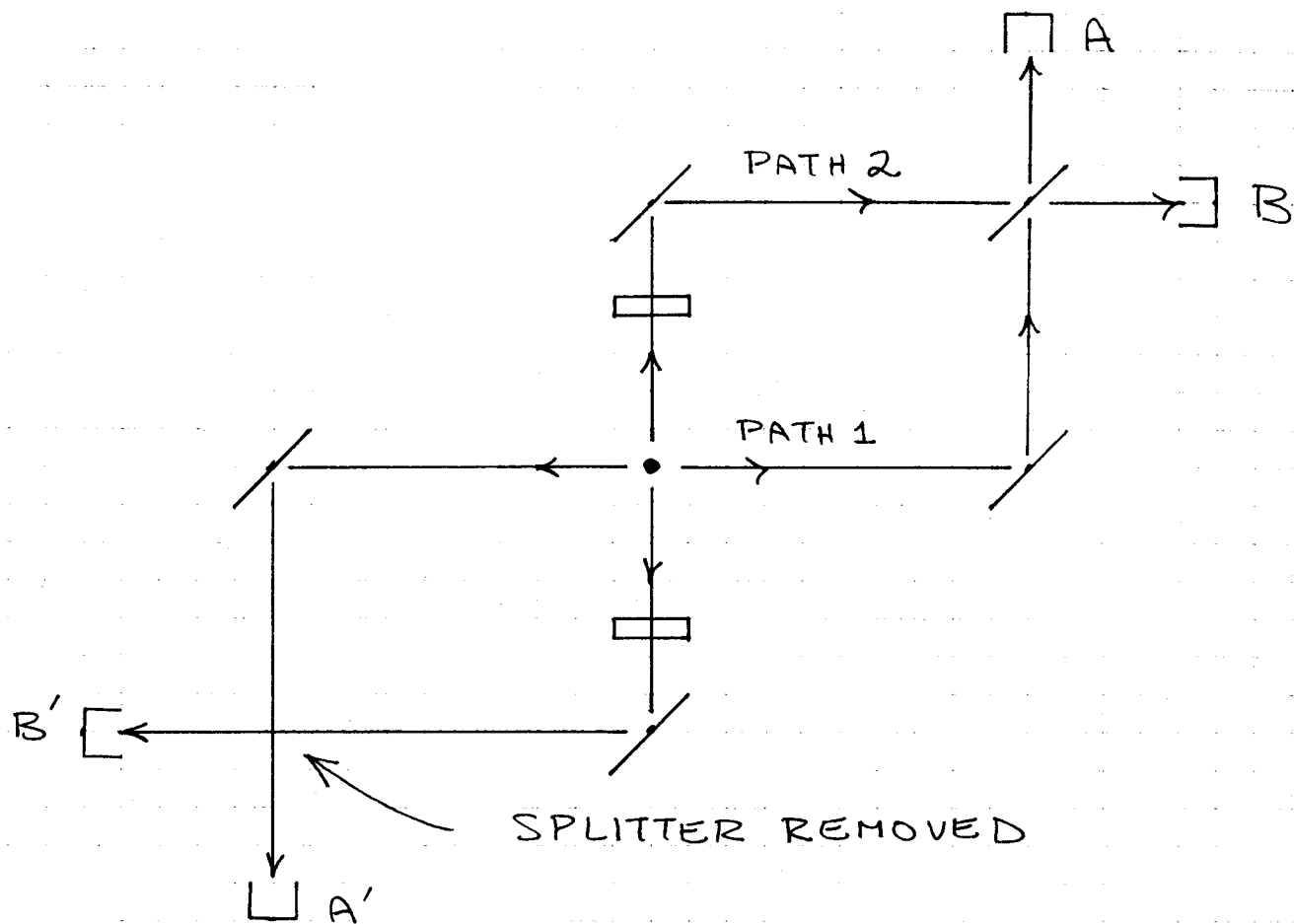

SIGNAL IN A' \Rightarrow OTHER PHOTON TOOK PATH 1
 \Rightarrow SIGNAL SPLIT BETWEEN A AND B

SIGNAL IN B' \Rightarrow OTHER PHOTON TOOK PATH 2
 \Rightarrow SIGNAL SPLIT BETWEEN A AND B

IF SIGNAL IS OBSERVED AT A, WE KNOW
 THAT THE SPLITTER HAS BEEN REMOVED
 FROM THE OTHER INTERFEROMETER

\Rightarrow SUPERLUMINAL CONNECTION!

R. C. TOLMAN (1917)

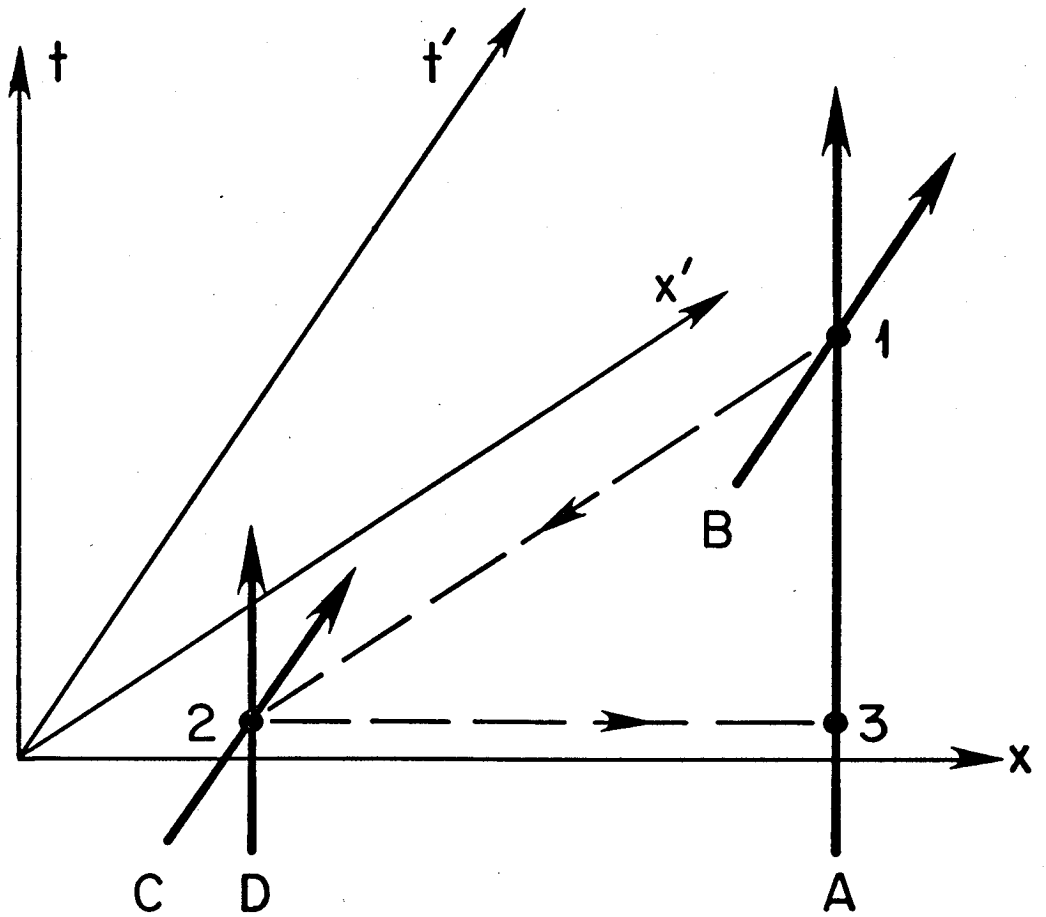

SUPERLUMINAL CONNECTIONS

+ SPECIAL RELATIVITY

\Rightarrow COMMUNICATION FROM FUTURE
INTO THE PAST

RESOLUTION OF THE PARADOX (KITAZAWA)

BE CAREFUL TO SPECIFY THE WAVE FUNCTION OF THE TWO γ 'S PROPERLY

$$\Psi = \frac{1}{\sqrt{2}} (\Psi_1 \Psi'_1 + \Psi_2 \Psi'_2)$$

Ψ, Ψ' LABEL γ 'S IN THE 1ST AND 2ND INTERFEROMETERS

1, 2 LABEL THE PATHS

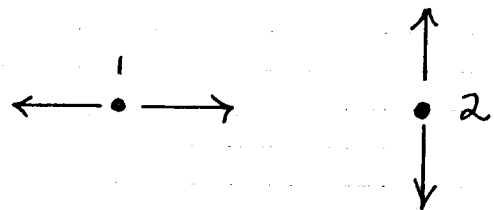

PROJECT THE WAVE FUNCTION ONTO A BASIS

DEFINED BY THE DETECTORS:

$$\left. \begin{aligned} \Psi_A &= \frac{1}{\sqrt{2}} (\Psi_1 - \Psi_2) & \Psi_B &= \frac{1}{\sqrt{2}} (\Psi_1 + \Psi_2) \\ \text{so } \Psi_1 &= \frac{1}{\sqrt{2}} (\Psi_A + \Psi_B) & \Psi_2 &= \frac{1}{\sqrt{2}} (\Psi_B - \Psi_A) \end{aligned} \right\} \begin{array}{l} \text{IF THE} \\ \text{SPLITTER} \\ \text{IS PRESENT} \end{array}$$

$$\begin{aligned} \Psi &= \frac{1}{2\sqrt{2}} \left\{ (\Psi_A + \Psi_B)(\Psi'_A + \Psi'_B) + (\Psi_B - \Psi_A)(\Psi'_B - \Psi'_A) \right\} \\ &= \frac{1}{\sqrt{2}} \left\{ \Psi_A \Psi'_A + \Psi_B \Psi'_B \right\} \end{aligned}$$

\Rightarrow WE ACTUALLY OBSERVE BOTH COMBINATIONS (AA') AND (BB') WHEN BOTH SPLITTERS ARE PRESENT. BUT NOT (AB') OR (BA').

IF THE 2ND SPLITTER IS ABSENT

$$\psi_{1'} = \psi_{A'} \quad \psi_{2'} = \psi_{B'}$$

$$\begin{aligned} \psi &= \frac{1}{2} \{ (\psi_A + \psi_B) \psi_{A'} + (\psi_B - \psi_A) \psi_{B'} \} \\ &= \frac{1}{2} \{ \psi_A \psi_{A'} - \psi_A \psi_{B'} + \psi_B \psi_{A'} + \psi_B \psi_{B'} \} \end{aligned}$$

⇒ ALL 4 COMBINATIONS ARE OBSERVED.

HENCE OBSERVATIONS AT A AND B ALONE
CANNOT TELL US ABOUT THE STATE OF THE
APPARATUS AT A' OR B' FAR AWAY.

⇒ NO SUPERLUMINAL CONNECTION !!

(Noted added Nov. 3, 2003)

A moral of this story is that the wave function of an entangled state cannot be written as the tensor product of states of its components:

$$\psi_{\text{entangled}} \neq \psi\psi'$$

As a further example of this principle, consider a variant of the setup on p. 48 in which the beam splitter is in place in interferometer 1, but the 2nd interferometer is absent and the 2nd photon is never observed. We might be tempted to argue that since the state of the 2nd photon is never observed, the components of its wave function $\psi' = (\psi_{1'} + \psi_{2'})/\sqrt{2}$ can be taken as equal: $\psi_{1'} = \psi_{2'} = 1$.

If so, the wave function ψ for the 2-photon system could be written

$$\psi = \frac{1}{\sqrt{2}} (\psi_1\psi_{1'} + \psi_2\psi_{2'}) = \frac{1}{\sqrt{2}} \left[\frac{1}{\sqrt{2}} (\psi_A + \psi_B) + \frac{1}{\sqrt{2}} (\psi_B - \psi_A) \right] = \psi_B.$$

Then, we always observe a photon in detector B, and never in detector A (as was found to be the case for a single interferometer 5 slides ago).

Can this result actually hold?

If the 2nd photon is observed, we have shown that the first photon will be observed in detectors A and B with 50% probability. If in a set of experiments the first photon is only found in detector B, the above analysis would imply that the 2nd photon was never observed, even at times arbitrarily long after the first photon was observed. This appears to contradict our freedom to make a delayed choice to observe the 2nd photon.

Even though the 2nd photon is not observed, a proper description of the entangled wave function of the two-photon system must take into account the possibility that if the photon were observed, different results would be possible. That is, we should write $\psi_{1'} = \psi_{A'}$ and $\psi_{2'} = \psi_{B'}$ where the states $\psi_{A'}$ and $\psi_{B'}$ are distinguishable. Then, as discussed on the previous slide, the wave function for the system should be written

$$\psi = \frac{1}{2} (\psi_A\psi_{A'} + \psi_A\psi_{B'} + \psi_B\psi_{A'} + \psi_B\psi_{B'}),$$

from which we conclude that if we only observe photon 1 it will be found in detector A with 50% probability, and of course in detector B with the same probability.

An entangled 2-photon state does not behave like a pair of 1-photon states.